

February 2, 1998
Supersedes TIP AN16, AN56, CN15, CN55
Pages 1-20, Dated 1/1/94

ECN01, ECN02, ECN05, ECN06, ECN07
AN16, AN56, CN15 & CN55
Sizes 00-9, 600V Max.
Non-Reversing & Reversing
NEMA Type Enclosures 1, 3R, 4X & 12
Details On UL & cUL Listing and CSA Certified
Included In This TIP

NEMA Contactors & Starters (Freedom)

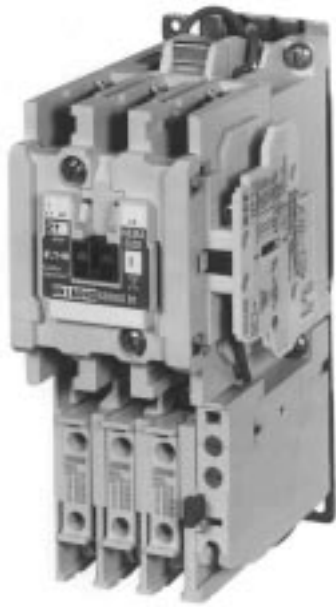

SIZE 1
NON-REVERSING STARTER



SIZE 3
NON-REVERSING STARTER

DESIGN CHARACTERISTICS

- **Overload Relays** — Bimetallic Ambient Compensated

Features include:

- Selectable Manual or Automatic Reset operation.
- Interchangeable Heater Packs $\pm 24\%$ to match motor FLA and calibrated for 1.0 and 1.15 service factors.
- Heater packs for Size 00-0 overload relays will mount in larger Size 1 and 2 overload relays — useful in derating applications such as jogging.
- Single phase protection — Class 20 or 10 trip time.
- Electrically isolated NO - NC contacts (pull RESET button to test).
- Visual trip indication
- Integral load lugs allows field wiring prior to heater pack installation.
- NEMA Sizes 5-9 use Current Transformer with 32 Amp overload. Size 5 uses 300:5 CT, Size 6 uses 600:5 CT, Size 7 uses 1000:5 CT, Size 8 uses 1500:5 CT, and Size 9 uses 3000:5 CT.

- **Magnet Coil** — Encapsulated dual voltage/frequency — color coded and permanently marked with voltage, frequency and part number.

A two-piece spring latch contactor design makes coil removal or replacement fast and simple for Sizes 00-2.

The NEMA Size 3-5 features a quick change coil assembly which makes coil removal and replacement fast and simple.

Coil terminals are located on top for easy accessibility. The Size 00 and 0 contactor magnet coils have three terminals, permitting either top or diagonal wiring — European or U. S. style starters can be replaced without changing wiring layout.

The NEMA Sizes 6-8 features a special DC feeder group for coil feeding. This system allows AC or DC applied voltage, low noise and low inrush and holding consumption.

The NEMA Size 9 coil is 110V dc/120V ac (Rectified). AC or DC magnet coils.

- **Contacts** — Long life twin break contacts provide excellent conductivity and superior resistance to welding and arc erosion. Generously sized for low resistance resulting in extended life.



NEMA, Contactors & Starters, (Freedom)

DESIGN CHARACTERISTICS (Continued)

- **Terminals** — Size 00 through 1 ± screw type with captive, backed-out self-lifting pressure plates. Finger proof covers, to reduce electrical shock, are available. Size 2-9:
Control: Back-out saddle clamp with ± screws
Power: Box lugs, pressure type
- **Mounting Position** — Sizes 00-5: Horizontal or vertical on upright panel. Sizes 6-8: 25° from vertical maximum. Size 9: Vertical only.
- **Connections** — Straight through wiring — Line lugs at top, load lugs at bottom.
- **Standards** —
UL listed (Size 00-8):
Open — File #E1491, Guide #NLDX
Enclosed — File #E19224, Guide #NLDX
UL listed (Size 9):
Open and Enclosed — File #E19224, Guide #NLDX
Except Size 9 Reverser Not UL Listed.
cUL listed (Size 00-8):
Enclosed — File #E19224, Guide #NLDX
CSA certified — (Size 00-8):
Open — File #LR353, Class #3211-04
Designed to meet or exceed NEMA standards.
- **Ambient Temperature** — -5°C to + 65°C
- **Enclosures** — Open or NEMA 1, 3R, 4X, and 12 enclosed. Snap-on cover control kits Size 00-4 NEMA 1; flange mount all other enclosure types.
- **Construction** — Designed specifically for use in applications requiring NEMA ratings. Starters meet or exceed NEMA standards ICS 2-1988.
- **Mechanical/Electrical Life** — Designed to 30 million mechanical operations at maximum HP ratings for Sizes 00 & 0, 10 million for Sizes 1 & 2, 5 million for Sizes 3-8. Designed to 3 million electrical operations for Sizes 00-3 and 500 thousand for Sizes 4-8. Size 9 mechanical life in excess of 24K operations and electrical life AC-3 (N/A); AC-4 in excess of 50 operations.
- **Wiring** — Wired for separate or common control.
- **Holding Circuit Interlock** — NEMA Starters Sizes 0-3 are supplied with 1 NO auxiliary contact mounted on the right hand side. On Size 00, interlock occupies 4th power pole position — no increase in width. Sizes 4 and 5 have NO interlock on left side, Sizes 6 and 7 have a 2NO/2NC auxiliary mounted on top between arc-chutes and Size 8 has NO/NC auxiliary on left side and a NO on the right. Size 9 supplied with 2 auxiliary contacts. Each with 1 NO & 1 NC.
- **Mounting** — Supplied with steel mounting plate as standard.

OPTIONAL FEATURES

- **Auxiliary Contacts** — Open type starters will accept up to 8 NO or NC auxiliary contacts (4 for Size 8) — includes holding circuit interlock. Enclosed contactors and starters will accept up to 4 NO or NC auxiliary contacts up to Size 1 in NEMA 1 enclosures. For larger sizes and other NEMA type enclosures, up to 8 NO or NC auxiliary contacts can be added.
- **Mechanical Interlock & Reversing Kits** — Available for field assembly of reversing contactors/starters up to Size 7.
- **Timer** — Two types — Side mounted five function Solid-State timer with timing ranges up to 5 minutes for use with open or enclosed starters/contactors, and top mounted pneumatic timers convertible from OFF to ON delay with timing ranges up to 3 minutes for use with open starters/contactors. Sizes 00-5 only.
- **Transient Suppressor Kit** — Limit high voltage transients produced in the control circuit when power is removed from the coil. For Sizes 00 through 2 there are three separate panel-mounted suppressors for use on 120, 240 or 480 volt coils. For Sizes 3 through 5 there is one separate side mounted suppressor for use on 120 volt coils.
- **Control Circuit Fuse Block** — Sizes 00-2 panel mounted and Sizes 3-5 side mounted fuse holder for control circuit protection. Uses Class CC rejection type fuses, 30 ampere, 600 volt ac maximum.
- **Locking Cover for Overload Relay** — Snaps over top of overload relays to prevent accidental turning of trip or reset adjustments.
- **Branch Circuit Fuse Block Kits** — Sizes 00 through 2, 3-pole, top-mounted. Provide short circuit protection for branch circuits.
- **Phase Monitor Relays** — Designed to monitor phase voltage unbalance, incorrect phase sequence and line undervoltage of a 3 phase system. Sizes 00-5 only.
- **Cover Controls for Enclosures** — Numerous push-buttons, selector switches and indicating lights are available either factory installed or as kits to be installed by others. These local control devices are available for NEMA 1, 3R, 4X and 12 enclosures.
- **Other Options for Enclosures** — Many other optional features such as meters, terminal strips, relays timers, control power transformers, fuse blocks and other accessories are available for installation in enclosed contactors and starters.

DESCRIPTION

Non-Reversing Starters

Line voltage magnetic starters are used for starting polyphase squirrel cage motors when full starting torque and the resulting inrush current are acceptable. These starters also provide protection to the motor against running or stalled overcurrents.

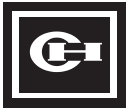

NEMA, Contactors & Starters, (Freedom)

The "Freedom Series" starters feature a compact space saving design using state-of-the-art technology and the latest in high strength, impact and temperature resistant insulating materials.

Reversing Starters

Three phase, full voltage magnetic starters are used primarily for reversing of polyphase squirrel cage motors. They consist of two contactors and a single overload relay assembled together. The contactors are mechanically and electrically interlocked to prevent line shorts and energization of both contactors simultaneously.



SIZE 1
REVERSING
STARTER



SIZE 0
REVERSING
STARTER

GENERAL

Magnet Coil — Magnet coils are encapsulated dual voltage/frequency coils which are color coded and permanently marked with voltage, frequency and part number. Coil terminals are located on top for easy accessibility.

Overload and Heater Packs — Overload relays used on "Freedom Series" starters come in four sizes — 32 amperes, 75 amperes, 105 amperes and 144 amperes. They can be attached directly to contactors (panel mount or common mounting plate) or, with a panel mounting adapter, as a stand alone panel mounted 32 ampere or 75 ampere overload relay. The panel mounting adapter also provides a terminal block for line side wiring to the stand alone overload relay. Sizes 5-9 use 32 amps with CT's.

The overload relay houses an adjustable, trip-free mechanism and provides mounting for three heater packs. The mechanism is bimetallic with ambient compensated operation. Single phase protection is built in. The reset mechanism can be set for AUTO or MANUAL operation. It has $\pm 24\%$ adjustability to match motor full load ampere rating with calibration for 1.0 or 1.15 service factor motors. Two isolated contacts, one NC and one NO can be tested by pulling the RESET button. The NC and NO contacts are rated B600 and C600 (refer to Ratings tables on Page 8) respectively. Like the contactor, the overload relay has "finger proof" terminals to reduce the possibility of electrical shock.

Tamper proof overload relay adjustment locking covers snap over the top of overload relays to prevent accidental turning of trip or reset adjustments. Consult the Industrial Control Catalog for information on the variety of covers available.

Visual trip indication is provided on all overload relays. The indicator window is located on the lower right-hand corner of the switch unit, just below the reset button. Upon an overload trip (or by pulling up on the reset button), a fluorescent orange indicating flag will appear in the window. Trip indication is only present when using Manual Reset.

CLASS 10
TYPE C306
OVERLOAD
RELAY

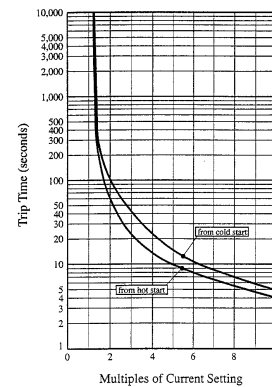

TRIP CURVE
TYPE C306 BIMETALLIC COMPENSATED
OVERLOAD RELAY 25°C OPEN RATING

CLASS 20
TYPE C306
OVERLOAD
RELAY

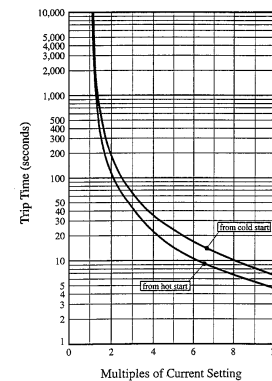

TRIP CURVE
TYPE C306 BIMETALLIC COMPENSATED
OVERLOAD RELAY 25°C OPEN RATING

The heater packs are securely held in the overload relay by two captive screws. Three Class 20 (Class 10 optional) heater packs are installed in the overload relay. The 32 ampere heater packs will mount in the 75 ampere overload relay for applications where the contactor is derated such as for jogging.

The overload relay is adjustable within the FLA range of the heater pack and will ultimately trip at 125% motor current. After the heater packs are selected and installed in the overload relay, the FLA adjustment dial should be rotated to the dial position corresponding to the motor FLA.

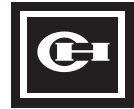

NEMA, Contactors & Starters, (Freedom)

Diagram	Heater Pack Selection Table ①				
	Motor FLA Rating				Heater Pack Number
	FLA Dial Positions				
A	B	C	D		
18.0	20.2	22.3	24.5	H2018-3	
24.6	27.6	30.5	33.4	H2019-3	
33.5	37.5	41.5	45.6	H2020-3	
45.7	51.2	56.7	62.1	H2021-3	
62.2	69.7	77.1	84.6	H2022-3	
84.7	95.0	105.0	115.0	H2023-3	
106.0	118.0	131.0	144.0	H2024-3	

① Example of Heater Pack Selection Table only. Refer to catalog for complete table.

For example, if the FLA rating is 75.2 amperes, heater packs number H2022-3 should be selected from the above listed Heater Pack Selection Table. For a 1.15 service factor motor the FLA adjustment dial should be set at the location shown in the above diagram by interpolating between the B position of 69.7 amperes and the C position of 77.1 amperes. If a 1.0 service factor motor would be involved, the dial should be rotated counterclockwise one graduation (one half position) to the dotted location in the diagram.

Power Poles — Power poles are available for the Sizes 00, 0, 1 and 2 contactors and starters only. The 00 & 0 power pole is rated 12 amps (20 amp thermal) and the 1 & 2 is rated the same as the basic devices.

A maximum of two power poles can be used per contactor or starter. They cannot be field or factory installed. The power poles have been designed to accept mechanical interlocks and side mounted auxiliary contacts.

General Auxiliary Contacts Information — Auxiliary contact blocks are designed for snap-on installation — fast, easy installation (no tools required). Side mounted contact blocks are available in 8 different circuit configurations — top mounted contact blocks are offered in 21 different combinations. Enclosed type starters will accept side-mounted auxiliaries only when mounted in standard enclosures. In larger enclosures, top mounted contacts can be added.

All auxiliary contacts are of the bifurcated design with parallel circuit paths. This redundant path provides very high reliability.

For rating information, refer to the “Auxiliary Contact Ratings” table in this publication on Page 8.



Side Auxiliary Contacts — All starters are supplied as standard with one normally open (1 NO) auxiliary contact for use as a holding circuit contact. Reversing starters have in addition, one normally closed (1 NC) auxiliary contact for electrical interlocking purposes.

On Size 00, the holding contact occupies the 4th power pole position (no additional space required). Up to two additional contacts may be added to each side of a Size 00 starter. On Sizes 0-2, the NO holding contact is located on the right side of the contactor. Up to two additional contacts may be added to the left side.

On Sizes 3-5, the NO holding contact is a base contact (on the right on Size 3 and on the left on Sizes 4 & 5). Up to 2 additional contacts can be mounted on the base interlock. On the opposite side, up to 4 additional auxiliary contacts can be added.

On Sizes 6 & 7, there is 2NO/2NC contact block mounted on the top-left position. An additional 2NO/2NC block may be added to the top-right position. On Size 8, there is a NO/NC block on the left back and a NO on the right back. Additional NO/NC blocks may be added on the left and right front positions.

On Size 9, 2 auxiliary contacts are provided, each with 1 NO and 1 NC.

Top Auxiliary Contacts — Open type starters, Sizes 00-2, will accept top auxiliary contacts (up to four circuits possible). This allows a total of up to 8 extra auxiliaries on Size 00 (6 extra auxiliaries on Sizes 00-2).

Electronic Timer — The side mounted, five-function Electronic Timer attachment has a 1 NO - 1 NC relay output and is designed for easy installation to any Freedom Series starter. It is available in three different timing ranges from 0.3 to 300 seconds. Additional auxiliary contacts cannot be installed on same side of starter when timer is used. For Sizes 3-5 a separate mounting bracket is required.



ELECTRONIC TIMER MODULE

- Timing Modes
 - ON DELAY - Timing begins when timer is energized.
 - OFF DELAY - Timing begins when timer is deenergized.
 - ONE SHOT - A single pulsed output occurs when timer is energized.

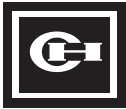

NEMA, Contactors & Starters, (Freedom)

- ON DELAY/OFF DELAY - Timer delay occurs on both energization and deenergization of timer.
- CYCLE MODE - Dual delay with external connections to the NC output contact, cycles ON and OFF continuously.

Delay mode is selectable with two switches on the face of the timer. The time is set by a serrated dial on the module face. Timer can also be mounted directly on 35 mm DIN rail.

• Specifications

- Repeat Accuracy – within $\pm 1\%$
- Setting Accuracy – $\pm 10\%$ of scale setting

Description	Maximum Current Rating, Amperes		
	Volts, ac		Volts, dc (Resistive)
	120	240	30
Make	30	15	5
Break	3	1.5	5
Continuous	3	1.5	5

Pneumatic Timer — The Pneumatic Timer attachment is designed for snap-on installation to top of any Size 00-2 starter (top mounted auxiliary contacts cannot be installed on device when timer is used). It is available in two ranges from 0.1 to 180 seconds. Timer unit has D.P.D.T. timed contacts – circuits in each pole must be the same polarity. Units are convertible from OFF to ON delay or vice-versa. Contacts are rated A600. Repeat accuracy is $\pm 10\%$.

PNEUMATIC TIMER ATTACHMENT



DC/AC Interface Module — The Interface Module is an optically isolated solid state switch which provides a means of operating ac coils with a 24 volt dc control signal. It acts as a space saving interposing relay which can switch a 110-240 volt, 50/60 Hz source to the contactor or starter coil.

The module may be directly attached to the coil terminals of any Freedom Series contactor or starter - Size 00-2. It also has provisions for DIN rail mounting.



INTERFACE MODULE

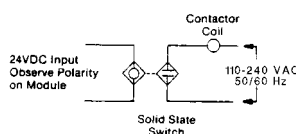

TYPICAL APPLICATION

DC Magnet Coils — Dc Magnet Coils are available either factory installed or as field conversion kits.

Transient Suppressor Kit — Sizes 00-2 device connects across terminals on any 120 V, 240 V or 480 V starter magnet coil and Sizes 3-5 side mounted device connects across terminals on a 120 volt starter magnet coil. Suppressors are designed to limit the high voltage transients produced in the circuit when power is removed from the coil.

TRANSIENT SUPPRESSOR KITS



FOR SIZES 00-2



FOR SIZES 3-5

Control Circuit Fuse Block — Size 00-2 panel mounted and Size 3-5 side mounted fuse holders, designed for control circuit protection or other similar low current requirements, have extractor type fuse caps.

The Class CC rejection type fuses (KTK-R) used in these holders are intended for use with equipment designated as being suitable for use on systems having high available fault currents.

If branch circuit protective device is 45 amperes or greater, C320FBR1 fuse kit may be required for control circuit protection per NEC 430-72.



CONTROL
CIRCUIT
FUSE BLOCK

3-Pole Top Mounted Branch Circuit Fuse Block Kits —

Designed to save space and reduce installation time, these top mounted fuse block kits field mount to any Size 00-2 starter and provide short circuit protection for branch circuits. Available for Class H, R, G or T fuses rated 15 through 60 amperes and Class J fuses rated 15 through 100 amperes, 250 through 600 volts.

MOUNTED FUSE
BLOCK



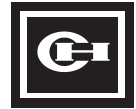

NEMA, Contactors & Starters, (Freedom)

Mechanical Interlock and Reversing Kits — These kits are available for field assembly of reversing starters using components. The Reversing Kits include a mechanical interlock, stabilizer bar and a pre-cut, trimmed and formed wire set. Auxiliary contacts are not supplied but can be ordered separately. The snap-fit mechanical interlock and stabilizer bar do not require tools for assembly. Installation instructions are included with the device.



Phase Monitor Relay — Phase Monitor Relays are designed to monitor phase voltage unbalance, incorrect phase sequence and line undervoltage of a 3 phase system.

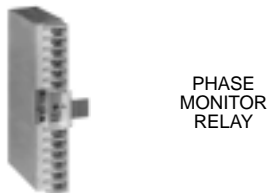

Finger Protection Shields — Snap-on shields for both contactors and starters, reversing and non-reversing provides type IP20 Finger Protection. Prevents accidental contact with line load terminals.



Overload Locking Covers — Snap-on transparent or opaque plastic panel for covering access port to the overload relay trip setting dials. Helps prevent accidental or unauthorized changes to trip reset setting. Five varieties offers maximum application flexibility.



Short Circuit Protection — Fuses and Inverse-Time Circuit Breakers may be selected per Article 430, Part D of the National Electrical Code to protect motor branch circuits from fault conditions. If higher ratings or settings are required to start the motor, do not exceed the maximum as listed in Exception No. 2, Article 430-52.

ENCLOSURES

NEMA Definitions

Type	Definition
1	Enclosures are intended for indoor use primarily to provide a degree of protection against limited amounts of falling dirt.
3R	Enclosures are intended for outdoor use primarily to provide a degree of protection against rain, sleet, and damage from external ice formation.
4X	Enclosures are intended for indoor or outdoor use primarily to provide a degree of protection against corrosion, windblown dust and rain, splashing water, hose-directed water, and damage from external ice formation.
12	Enclosures are intended for indoor use primarily to provide a degree of protection against circulating dust, falling dirt, and dripping noncorrosive liquids.



ENCLOSED STARTERS

Cover Control Kits for Enclosures — These kits are available for NEMA 1 enclosures in versions such as Start/Stop, Hand-Auto, Hand-Off-Auto, Test-Off-Auto — all available with and without pilot light options. For reversing applications, Forward-Stop-Reverse, Up-Stop-Down and Open-Stop-Close with and without pilot lights are available. For other NEMA types, these and other versions such as On-Off are available. The kits are complete with wires and instructions. Assembly is fast and easy, requiring only a screwdriver in most cases. NEMA 1 enclosures have removable blank plates or knockouts and NEMA 3R, 4X and 12 enclosures have removable hole plugs that cover the pre-punched holes.



ISLAND & 10250T TYPE COVER CONTROL WITH ACCOMPANYING ENCLOSURES

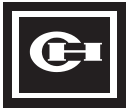

NEMA, Contactors & Starters, (Freedom)

REFERENCE DATA

NEMA AN16 Starters — High Fault Current Circuit Ratings — UL508

SCPD	Max Rating SCPD (A)	Cir Bkr Intrap Rating (KA)	Short Circuit Volt (V)	Withstand Current (KA)	Typical Disconnect
Size 00					
Data To Be Available Later					
Size 0					
Class R, J Fuse ①	60	100	600	100	C361
Mag Bkr — HMCP ①	30	100	480	100	HMCP
Thrm Mag — FDC ①	35	100	480	100	FDC
Size 1					
Class R, J Fuse ①	60	100	600	100	C361
Mag Bkr — HMCP ①	30	100	480	100	HMCP
Thrm Mag — FDC ①	90	100	480	100	FDC
Size 2					
Class R, J Fuse ①	100	100	600	100	C361
Mag Bkr — HMCP ①	50	100	480	100	HMCP
Thrm Mag — FDC ①	150	100	480	100	FDC
Size 3					
Class R, J Fuse ①	200	100	600	100	C361
Mag Bkr — HMCP ①	150	100	480	100	HMCP
Thrm Mag — FDC ①	150	100	480	100	FDC
Size 4					
Class R, J Fuse ①	400	100	600	100	400 A K SW
Mag Bkr — HMCP ①	150	100	480	100	HMCP
Thrm Mag — JDC ②	250	100	480	100	JDC
Size 5					
Class R, J Fuse ①	600	100	600	100	600 A K SW
Mag Bkr — HMCP ②	600	100	480	100	HMCP
Thrm Mag — KDC ②	400	100	480	100	FDC
Size 6					
Class L Fuse ①	1200	---	600	100	800 A K SW
Class L Fuse ①	1200	---	600	100	Mld Case N Fr
Thrm Mag — HLD ②	800	65	480	65	HLD

① UL File E39943 — Issue Date 2/15/89.

② UL File E47048 — Issue Date 11/23/87.

NOTE:

UL 508 STANDARD FAULT CURRENT RATINGS: All devices are UL Listed with fuses and inverse time circuit breakers to standard low level fault currents based on horsepower. All AN16 starters conform. Sizes 00-3 to 5kA. Sizes 4-5 to 10kA. Size 6 to 18kA. Size 7 to 30kA. Size 8 to 42kA and Size 9 to 85kA.

Electrical Data

NEMA Size	Frame Width	Ampere Rating, Continuous	Maximum Horsepower		
			Motor Voltage 60 Hz	1 φ	3 φ
00	45 mm	9	115	1/3	---
			200	---	1 1/2
			230	1	1 1/2
			460	---	2
			575	---	2
0	45 mm	18	115	1	---
			200	---	3
			230	2	3
			460	---	5
			575	---	5
1	65 mm	27	115	2	---
			200	---	7 1/2
			230	3	7 1/2
			460	---	10
			575	---	10
2	65 mm	45	115	3	---
			200	---	10
			230	7 1/2	15
			460	---	25
			575	---	25
3	90 mm	90	115	---	---
			200	---	25
			230	---	30
			460	---	50
			575	---	50
4	180 mm	135	115	---	---
			200	---	40
			230	---	50
			460	---	100
			575	---	100
5	180 mm	270	115	---	---
			200	---	75
			230	---	100
			460	---	200
			575	---	200
6	220 mm	540	115	---	---
			200	---	150
			230	---	200
			460	---	400
			575	---	400
7	280 mm	810	115	---	---
			200	---	200
			230	---	300
			460	---	600
			575	---	600
8	334 mm	1215	115	---	---
			200	---	400
			230	---	450
			460	---	900
			575	---	900
9	813 mm	2250	115	---	---
			200	---	---
			230	---	800
			460	---	1600
			575	---	1600



NEMA, Contactors & Starters, (Freedom)

Auxiliary Contact Ratings

NEMA Electrical Rating Designation	Volts	Amperes		
		Make	Break	Continuous
A600	120	60	6	10
	240	30	3	
	480	15	1.5	
	600	12	1.2	
B600	120	30	3	5
	240	15	1.5	
	480	7.5	0.75	
	600	6	0.60	
C600	120	15	1.5	2.5
	240	7.5	0.75	
	480	3.75	0.38	
	600	3.00	0.30	

Wire (75°C) Sizes — AWG or kcmil – Open and Enclosed

NEMA Size	Cu Only
Power Terminals — Contactors	
00	#12 – #16 Stranded, #12 – #14 Solid
0	#8 – #16 Stranded, #10 – #14 Solid
1	#8 – #14 Stranded or Solid
2	#3 – #14 (upper) and/or #6 – #14 (lower) Stranded or Solid ②
Power Terminals — Load (Overload Relay)	
Heater Pack Cat. Nos.	① Min. — Cu Only (Stranded or Solid)
H2001B-H2010B H2101B-H2110B	#14
H2011B & H2111B	#12
H2012B & H2112B	#10
H2013B-H2014B H2113B-H2114B	#8
H2015B & H2115B	#6
H2016B & H2116B	#4
H2017B & H2117B	#3
H2015A-H2017A H2114-H2117	#14-#2
Power Terminals – Line and Load	
3	#1/0 – #14 Al Cu
4	#3/0 – #8 Al Cu
5	750 kcmil – #2 or (2) 250 kcmil – #3/0 Al Cu
6	(2) 750 kcmil — #3/0 Al Cu
7	(3) 750 kcmil — #3/0 Al Cu
8	(4) 750 kcmil — #1/0 Al Cu
9	(8) 500 kcmil
Control Terminals — Cu Only	
All	#12 – #16 Stranded or #12 – #14 Solid

① Minimum per NEC.
Maximum Wire Size: Sizes 00 & 0 — #8 and Sizes 1 & 2 — #2.
② Two compartment box lug.

Torque Requirements — Line/Load and Heaters (in-lbs)

NEMA Size	AN16/56 Starters				
	Line Lug ④		Load Lug		Heater Packs in-lbs
	Torque in-lbs	Wire Range	Torque in-lbs	Wire Range	
00	7	③	20	③	9
0	15	③	20	③	9
1	20	③	35	#14-10	9
			40	#8	9
			45	#6-4	9
2	40	#14-8	35	#14-10	9
			45	#8	9
			50	#6-4	9
3	35	#14-10	35	#14-10	24-30
			40	#8	24-30
			45	#6-4	24-30
4	200	③	40	#3-1/0	24-30
			45	#3-1/0	24-30
			50	#3-1/0	24-30
5-7	550	③	550	③	9
8	500	③	500	③	9
9	400	4/0-500 MCM	400	4/0-500 MCM	9

③ See "Wire Sizes" Table adjacent.
④ For contactors this is "Line and Load Lug" data.

Plugging and Jogging Service Horsepower Rating

NEMA Size	200 Volts	230 Volts	460 Volts	575 Volts
Maximum horsepower where operation is interrupted more than 5 times per minute, or more than 10 times in a 10 minute period.				
00	---	1/2	1/2	1/2
0	1 1/2	1 1/2	2	2
1	3	3	5	5
2	7 1/2	10	15	15
3	15	20	30	30
4	25	30	60	60
5	60	75	150	150
6	125	150	300	300



NEMA, Contactors & Starters, (Freedom)

AC COIL DATA

NEMA Sizes	P.U. Volts		P.U.			Sealed			D.O. Volts		Mech. Max. Operation Rate Ops/Hour	P.U. Time mS	D.O. Time mS
	Cold	Hot	VAR	VA	Watts	VAR	VA	Watts	Cold	Hot			
00	74.0%	78%	64	80	49	7.1	7.5	2.4	45%	46%	10,800	12	12
0	74.0%	78%	78	100	65	9.2	10	3.1	45%	46%	10,800	12	12
1-2	74.0%	78%	210	230	95	27	28	7.8	49%	50%	7,200	20	14
3	72.0%	76%	374	390	112	48	49.8	13	50%	52%	7,200	14	11
4	72.5%	76%	1132	1158	240	96	100	27.2	54%	56%	4,800	28	14
5	75.0%	77%	1132	1158	240	96	100	27.2	63%	64%	4,800	25	13
6	75.0%	75%	516	890	798	---	11	10	①	①	2,400	100	150-1000 ②
7	75.0%	75%	868	1000	1345	11	25	20	①	①	1,200	100	150-1000
8	75.0%	75%	1262	2400	---	---	70	---	①	①	600	100	25-50
9	50.0%	65%	---	---	2100	---	---	350	40%	50%	---	18	20

① 20-30% of rated coil voltage.

② Adjustable drop out time.

DC COIL DATA

NEMA Sizes	Volts	P.U.			Sealed		D.O. Volts (Hot)	P.U. Time mS	D.O. Time mS	Max. Operation Rate Ops/Hour	Mech. Life Millions
		Amps	Watts	Volts (Hot)	Amps	Watts					
00/0	12	6.4	76.8	80%	0.28	3.36	60%	22	17	3,600	5
	24	3.2	76.8	80%	0.14	3.36	60%	22	17	3,600	5
	48	1.6	76.8	80%	0.07	3.36	60%	22	17	3,600	5
	120	0.64	76.8	80%	0.028	3.36	60%	22	17	3,600	5
1/2	12	15.4	126	68%	0.42	4.98	30%	21	12	3,600	2
	24	6.2	88.4	60%	0.21	4.96	29%	20	13	3,600	2
	48	2.9	76.2	56%	0.11	5.04	28%	20	14	3,600	2
	120	1.1	67.3	53%	0.041	4.87	29%	20	16	3,600	2
3	12	24	293	65%	0.40	4.84	23%	39	14	3,600	2
	24	12	288	61%	0.20	4.75	22%	38	14	3,600	2
	48	6.1	295	62%	0.097	4.67	22%	37	14	3,600	2
	120	2.5	298	61%	0.038	4.57	22%	37	16	3,600	2
4/5	24	18	400	67%	0.22	5.3	25%	53	14	2,400	2
	48	9.0	400	67%	0.11	5.2	25%	49	16	2,400	2
	120	3.3	450	65%	0.05	5.4	28%	56	19	2,400	2
	240	1.7	440	64%	0.02	4.9	26%	49	21	2,400	2
6	106	8.25	775	N/A	0.085	9	N/A	N/A	N/A	2,400	5
	214	4.09	775	N/A	0.042	9	N/A	N/A	N/A	2,400	5
	340	2.57	775	N/A	0.026	9	N/A	N/A	N/A	2,400	5
	430	2.03	775	N/A	0.021	9	N/A	N/A	N/A	2,400	5
7	106	13.92	1425	N/A	0.184	19.5	N/A	N/A	N/A	1,200	5 ③
	214	6.89	1425	N/A	0.091	19.5	N/A	N/A	N/A	1,200	5 ③
	340	4.34	1425	N/A	0.057	19.5	N/A	N/A	N/A	1,200	5 ③
	430	3.43	1425	N/A	0.045	19.5	N/A	N/A	N/A	1,200	5 ③
8	106	19.81	2100	N/A	0.566	60	N/A	N/A	N/A	600	5 ③
	214	9.81	2100	N/A	0.280	60	N/A	N/A	N/A	600	5 ③
	340	6.18	2100	N/A	0.176	60	N/A	N/A	N/A	600	5 ③
	430	4.88	2100	N/A	0.139	60	N/A	N/A	N/A	600	5 ③

③ Change armature, magnet and armature interlock after 1 x 10⁶ operations.

GENERAL COIL DATA

Coil Offering — Encapsulated — NEMA Sizes 00-9

(Except Size 6 is tape)

UL Insulation Rating — Encapsulated — Class 130 (B)

— 105 degree C temp. rise

Operational Limits — 85% to 110% of Rated Voltage

Coil Data Notes

P.U. = Pick up time is the average time taken from closing of the coil circuit to main contact touch.

D.O. = Drop out time is the average time taken from opening of the coil circuit to main contact separation.

Cold = Coil data with a cold coil.

Hot = Coil data with a hot coil.

All data is based on a standard contactor with no auxiliary devices and a 120 VAC or 24 VDC magnet coil. Coil data has a ±5% range depending on the application, therefore specific data may vary.

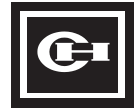

NEMA, Contactors & Starters, (Freedom)

RENEWAL PARTS

Magnet Coils					
Coil Volts and Hertz	Size 00 ①	Size 0 ①	Size 1-2	Size 3	Size 4-5
120/60 or 110/50	9-2823-1	9-2824-1	9-2703-1	9-2756-1	9-1891-1
240/60 or 220/50	9-2823-2	9-2824-2	9-2703-2	9-2756-2	9-1891-2
480/60 or 440/50	9-2823-3	9-2824-3	9-2703-3	9-2756-3	9-1891-3
600/60 or 550/50	9-2823-4	9-2824-4	9-2703-4	9-2756-4	9-1891-4
24/60 or 24/50	9-2823-18	9-2824-18	9-2703-16	9-2756-16	---
24/60	9-2823-7	9-2824-7	9-2703-6	9-2756-6	9-1891-15
48/60	9-2823-8	9-2824-8	9-2703-11	9-2756-15	---
208/60	9-2823-5	9-2824-5	9-2703-9	9-2756-5	9-1891-13
277/60	9-2823-12	9-2824-14	9-2703-7	9-2756-9	9-1891-26
24/50	9-2823-13	9-2824-13	9-2703-12	9-2756-11	9-1891-16
208-240/60	9-2823-17	9-2824-17	---	---	---
32/50	---	---	9-2703-10	9-2756-10	9-1891-27
48/50	9-2823-9	9-2824-9	9-2703-13	9-2756-7	9-1891-18
240/50	9-2823-11	9-2824-11	9-2703-14	9-2756-13	9-1891-20
380/50	---	---	---	9-2756-12	9-1891-14
415/50	---	---	---	9-2756-8	9-1891-21
380-415/50	9-2823-6	9-2824-6	9-2703-8	---	---
550/50	---	---	---	9-2756-14	9-1891-8
Coil Volts and Hertz		Size 6			
		Main Coil		Feeder Group	
120/60 or 110/50		9-3006		9-3007	
240/60 or 220/50		9-3006-2		9-3007-2	
480/60 or 440/50		9-3006-3		9-3007-3	
600/60 or 550/50		9-3006-4		9-3007-4	
218/60 or 200/50		9-3006-5		9-3007-5	
277/60 or 254/50		9-3006-6		9-3007-6	
415/60 or 380/50		9-3006-7		9-3007-7	
52/60 or 48/50		---		---	
110/50-60		---		---	
120/50-60		---		---	
208/50-60		---		---	
220/50-60		---		---	
240/50-60		---		---	
380/50-60		---		---	
415/50-60		---		---	
440/50-60		---		---	
480/50-60		---		---	
550/50-60		---		---	
600/60-50		---		---	
Coil Volts and Hertz		Size 7			
		Main Coil		Feeder Group	
120/60 or 110/50		9-2698		9-2705	
240/60 or 220/50		9-2698-2		9-2705-2	
480/60 or 440/50		9-2698-3		9-2705-3	
600/60 or 550/50		9-2698-4		9-2705-4	
415/60 or 380/50		9-2698-6		9-2705-6	
48/60 or 44/50		9-2698-8		9-2705-8	
208/50-60		9-2698-5		9-2705-5	

① These are the only renewal parts available. Series B1/C1 only.

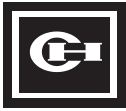

NEMA, Contactors & Starters, (Freedom)

RENEWAL PARTS

Magnet Coils (Continued)				
Coil Volts and Hertz	Size 8			
	Common Control		Separate Control	
	Main Coils	Feeder Group	Main Coils	Feeder Group
120/50-60 208/50-60 240/50-60 380/50-60 480/50-60 550/50-60 600/50-60	9-2654 9-2654-6 9-2654-2 9-2654-5 9-2654-3	9-2664 9-2664-6 9-2664-2 9-2664-5 9-2664-3	9-2654	9-2664
9-2654-10 9-2654-4	9-2664-10 9-2664-4			
Coil Volts and Hertz	Size 9			
	Common Control		Separate Control	
	5264C34G01		5264C34G01	
120/50-60				
Dc Coil Kits				
NEMA Contactor or Starter Size	Volts		Catalog Number	
00-0	12		C335KD3R1	
	24		KD3T1	
	48		KD3W1	
	120		KD3A1	
1-2	12		C335KD4R4	
	24		KD4T4	
	48		KD4W4	
	120		KD4A4	
3	12		C335KD5R1	
	24		KD5T1	
	48		KD5W1	
	120		KD5A1	
4-5	24		C335KA3T1	
	48		KA3W1	
	120		KA3A1	
	240		KA3B1	
Contact Kits				
Contactor or Starter NEMA Size	Part Numbers			
	2 Pole		3 Pole	
	1	6-65	6-65-2	
2	6-65-7	6-65-8		
3	6-43	6-43-2		
4	6-44	6-44-2		
5	6-45	6-45-2		
6 ①	---	6-648		
7	---	6-613		
8	---	6-571		
9	(2) — 5264C42G01	(3) — 5264C42G01		
Publications				
NEMA Size Starter	Publication Numbers			
1-2	22177			
3	20426			
4	20428			
5	20429			
6	23349			
7	20848			
8	20849			
9	IL 16978			

① Series B1 contactor, Series C1 starter.

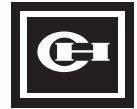

NEMA, Contactors & Starters, (Freedom)

APPROXIMATE DIMENSIONS AND SHIPPING WEIGHTS

Do not use for construction.

NON-REVERSING OPEN TYPE

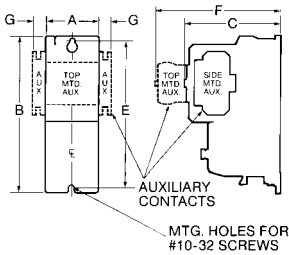

SIZE 00 & 0

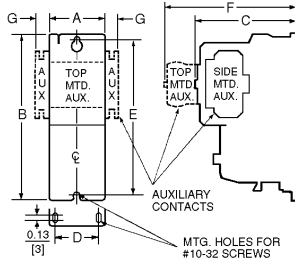

SIZE 1 & 2

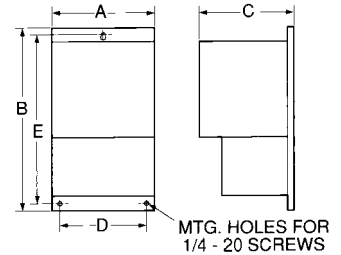

SIZE 3 & 4

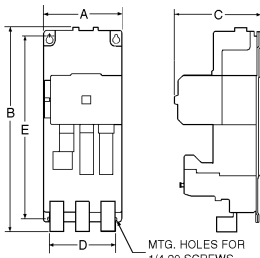

SIZE 5

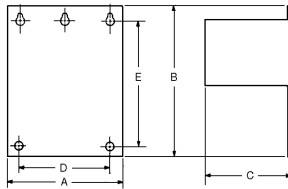

MOUNTING SCREWS — #1/2 - 13
SIZES 6 THROUGH 8

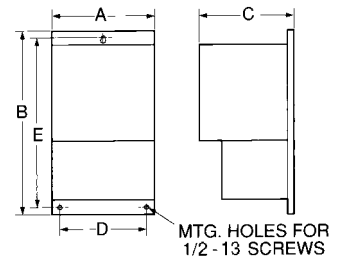

SIZE 9

NEMA Size	Dimensions in Inches [mm]							Shipping Weight Lbs.
	Wide A	High B	Deep C	Mounting		F	G	
				D	E			
00-0	1.80 [45.5]	6.60 [168]	3.52 [89.5]	---	6.07 [154]	4.90 [124.5]	0.54 [13.7]	2.2
1	2.56 [65]	7.08 [180]	4.44 [113]	2.00 [51]	6.63 [168]	5.80 [147.5]	0.54 [13.7]	4.5
2	2.56 [65]	8.08 [205]	4.44 [113]	2.00 [51]	7.63 [194]	5.80 [147.5]	0.54 [13.7]	4.7
3	4.08 [104]	11.35 [288]	5.94 [151]	3.00 [76]	10.81 [275]	---	---	11.
4	7.05 [179]	12.06 [306]	7.25 [184]	6.00 [152]	8.50 [216]	---	---	23.
5	7.00 [178]	17.77 [451]	7.76 [197]	6.00 [152]	16.00 [406]	---	---	36.
6	9.47 [241]	21.69 [551]	9.90 [251]	3.10 [79]	18.00 [457]	---	---	75.
7	15.13 [384]	29.13 [740]	12.64 [321]	13.25 [337]	21.25 [540]	---	---	120.
8	15.13 [384]	34.50 [876]	15.00 [381]	13.75 [337]	16.75 [425]	---	---	210.
9	33.00 [838]	30.00 [762]	12.94 [329]	30.75 [781]	8.00 [203]	---	---	315.

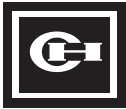

NEMA, Contactors & Starters, (Freedom)

APPROXIMATE DIMENSIONS AND SHIPPING WEIGHTS (Continued)

Do not use for construction.

REVERSING OPEN TYPE

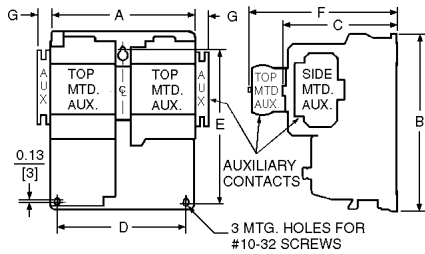

SIZE 00-2

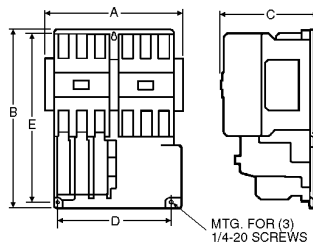

SIZE 3

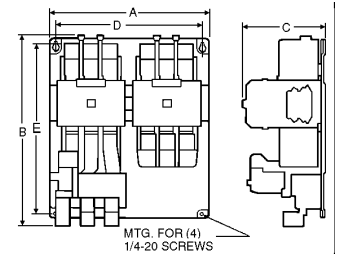

SIZE 4-5

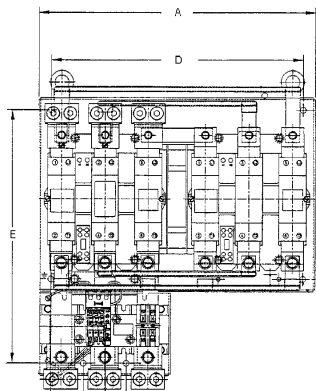

SIZE 6

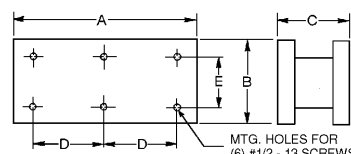
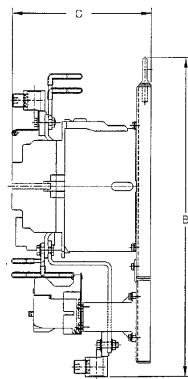

MOUNTING SCREWS #1/2 - 13
OPEN TYPE — SIZE 7-8 HORIZONTAL

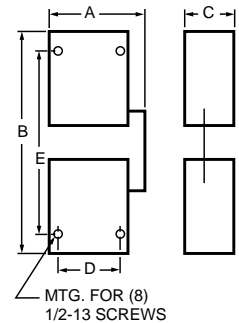

SIZE 9
OPEN TYPE — VERTICAL

NEMA Size	Dimensions in Inches [mm]							Shipping Weight Lbs.
	Wide A	High B	Deep C	Mounting		F	G	
				D	E			
00-0	4.20 [106.5]	7.38 [187.5]	3.52 [89.5]	3.50 [89]	6.87 [174.5]	4.90 [124.5]	0.54 [13.7]	3.6
1	5.71 [145]	7.08 [180]	4.44 [113]	5.25 [133.5]	5.75 [146]	5.80 [147]	0.54 [13.7]	8.25
2	5.71 [145]	8.08 [205]	4.44 [113]	5.25 [133.5]	6.75 [171.5]	5.80 [147]	0.54 [13.7]	8.5
3	8.70 [221]	11.35 [288]	5.94 [151]	7.00 [178]	10.81 [275]	---	---	20.
4	14.68 [373]	12.06 [306]	7.25 [184]	13.50 [343]	8.50 [216]	---	---	49.
5	14.50 [368]	17.77 [451]	7.76 [197]	13.50 [343]	16.00 [406]	---	---	68.
6	19.77 [502]	22.63 [575]	9.90 [251]	18.00 [457]	18.00 [457]	---	---	130.
7	28.06 [713]	32.13 [816] ❶	12.70 [322]	12.75 [324]	21.25 [540]	---	---	175.
8	30.38 [772]	41.50 [1054] ❶	14.70 [373]	14.13 [359]	16.75 [425]	---	---	430.
9	33.00 [838]	63.12 [1603]	12.94 [329]	30.75 [781]	41.00 [1041]	---	---	640.

❶ Includes cross wiring overhang.

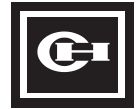

NEMA, Contactors & Starters, (Freedom)

APPROXIMATE DIMENSIONS AND SHIPPING WEIGHTS (Continued)

Do not use for construction.

NON-REVERSING & REVERSING CONTACTORS — ENCLOSED TYPE NEMA 1

NEMA Size (poles)	Box No.	Dimensions in Inches [mm]					Ship Wt. Lbs.
		Wide A	High B	Deep C	Mounting		
					Wide D	High E	
NON-REVERSING CONTACTORS - without Control Power Transformers							
00 (2P, 3P, 4P)	1	5.62 [143]	10.09 [256]	5.71 [145]	4.50 [114]	8.00 [203]	5.25
00 (2P, 3P, 4P) with top adders	2	7.73 [196]	13.21 [336]	6.75 [172]	6.00 [152]	10.75 [273]	7.3
0 (2P, 3P, 4P)	1	5.62 [143]	10.09 [256]	5.71 [145]	4.50 [114]	8.00 [203]	5.25
0 (2P, 3P, 4P) with top adders	2	7.73 [196]	13.21 [336]	6.75 [172]	6.00 [152]	10.75 [273]	7.3
0 (5P)	2	7.73 [196]	13.21 [336]	6.75 [172]	6.00 [152]	10.75 [273]	7.3
1 (2P, 3P)	1	5.62 [143]	10.09 [256]	5.71 [145]	4.50 [114]	8.00 [203]	7.9
1 (2P, 3P) with top adders	3	12.65 [321]	14.40 [366]	7.31 [186]	9.75 [248]	11.25 [286]	11
1 (4P, 5P)	2	7.73 [196]	13.21 [336]	6.75 [172]	6.00 [152]	10.75 [273]	8.5
2 (2P, 3P, 4P, 5P)	2	7.73 [196]	13.21 [336]	6.75 [172]	6.00 [152]	10.75 [273]	8.5
3 (2P, 3P)	4	11.66 [296]	26.51 [673]	8.89 [226]	9.00 [229]	23.38 [594]	35
4 (2P, 3P)	4	11.66 [296]	26.51 [673]	8.89 [226]	9.00 [229]	23.38 [594]	47
5	10	20.00 [508]	47.85 [1215]	11.36 [289]	14.50 [368]	46.25 [1175]	113
6		Consult Cutler-Hammer for Availability					
7							
8							
9							
NON-REVERSING CONTACTORS - with Control Power Transformers							
00 (2P, 3P, 4P)	2	7.73 [196]	13.21 [336]	6.75 [172]	6.00 [152]	10.75 [273]	12
00 (2P, 3P, 4P, 5P) with top adders	3	12.65 [321]	14.40 [366]	7.31 [186]	9.75 [248]	11.25 [286]	15
0 (2P, 3P, 4P, 5P)	2	7.73 [196]	13.21 [336]	6.75 [172]	6.00 [152]	10.75 [273]	12
0 (2P, 3P, 4P, 5P) with top adders	3	12.65 [321]	14.40 [366]	7.31 [186]	9.75 [248]	11.25 [286]	15
1 (2P, 3P)	2	7.73 [196]	13.21 [336]	6.75 [172]	6.00 [152]	10.75 [273]	12.2
1 (2P, 3P) with top adders	3	12.65 [321]	14.40 [366]	7.31 [186]	9.75 [248]	11.25 [286]	12.5
1 (4P, 5P)	2	7.73 [196]	13.21 [336]	6.75 [172]	6.00 [152]	10.75 [273]	12.6
2 (2P, 3P, 4P, 5P)	2	7.73 [196]	13.21 [336]	6.75 [172]	6.00 [152]	10.75 [273]	12.8
3 (2P, 3P)	4	11.66 [296]	26.51 [673]	8.89 [226]	9.00 [229]	23.38 [594]	40
4 (2P, 3P)	4	11.66 [296]	26.51 [673]	8.89 [226]	9.00 [229]	23.38 [594]	52
5	10	20.00 [508]	47.85 [1215]	11.36 [289]	14.50 [368]	46.25 [1175]	120
6		Consult Cutler-Hammer for Availability					
7							
8							
9							
3 POLE REVERSING CONTACTORS - without Control Power Transformers							
00	2	7.73 [196]	13.21 [336]	6.75 [172]	6.00 [152]	10.75 [273]	7.8
0	2	7.73 [196]	13.21 [336]	6.75 [172]	6.00 [152]	10.75 [273]	8
1	3	12.65 [321]	14.40 [366]	7.31 [186]	9.75 [248]	11.25 [286]	11
2	3	12.65 [321]	14.40 [366]	7.31 [186]	9.75 [248]	11.25 [286]	12
3	4	11.66 [296]	26.51 [673]	8.89 [226]	9.00 [229]	23.38 [594]	67
4	4	11.66 [296]	26.51 [673]	8.89 [226]	9.00 [229]	23.38 [594]	154
5	10	20.00 [508]	47.85 [1215]	11.36 [289]	14.50 [368]	46.25 [1175]	170
6		Consult Cutler-Hammer for Availability					
7							
8							
9							

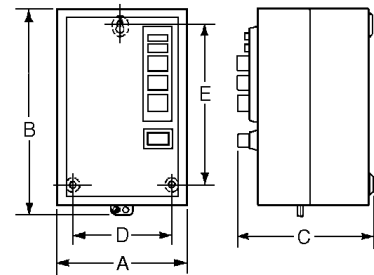

BOXES 1-4

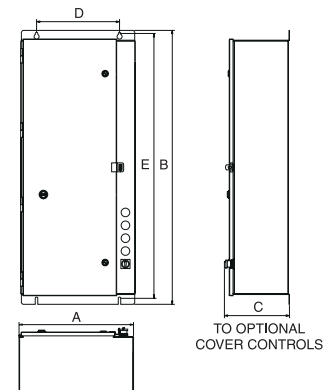

BOX 10

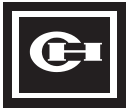

NEMA, Contactors & Starters, (Freedom)

APPROXIMATE DIMENSIONS AND SHIPPING WEIGHTS (Continued)

Do not use for construction.

NON-REVERSING & REVERSING CONTACTORS — ENCLOSED TYPE NEMA 3R, 4/4X & 12

NEMA Size (poles)	Box No.	Dimensions in Inches [mm]					Ship Wt. Lbs.
		Wide A	High B	Deep C	Mounting		
					Wide D	High E	
NON-REVERSING CONTACTORS - without Control Power Transformers							
0 (2P, 3P, 4P)	5	9.84 [250]	13.31 [338]	7.51 [191]	5.50 [140]	12.50 [3.18]	14
1 (2P, 3P, 4P, 5P)	5	9.84 [250]	13.31 [338]	7.51 [191]	5.50 [140]	12.50 [3.18]	15
2 (2P, 3P, 4P, 5P)	5	9.84 [250]	13.31 [338]	7.51 [191]	5.50 [140]	12.50 [3.18]	15.5
3 (2P, 3P)	8	14.25 [362]	29.10 [739]	9.29 [234]	9.00 [229]	27.50 [699]	45
4 (2P, 3P)	8	14.25 [362]	29.10 [739]	9.29 [234]	9.00 [229]	27.50 [699]	56
5	10	20.00 [508]	47.85 [1215]	11.36 [289]	14.50 [368]	46.25 [1175]	140
6		Consult Cutler-Hammer for Availability					
7							
8							
9							
NON-REVERSING CONTACTORS - with Control Power Transformers							
0 (2P, 3P, 4P)	5	9.84 [250]	13.31 [338]	7.51 [191]	5.50 [140]	12.50 [3.18]	18
1 (2P, 3P, 4P, 5P)	6	12.01 [305]	14.39 [366]	7.51 [191]	8.00 [203]	13.50 [343]	19
2 (2P, 3P, 4P, 5P)	6	12.01 [305]	14.39 [366]	7.51 [191]	8.00 [203]	13.50 [343]	19.5
3 (2P, 3P)	8	14.25 [362]	29.10 [739]	9.29 [234]	9.00 [229]	27.50 [699]	52
4 (2P, 3P)	8	14.25 [362]	29.10 [739]	9.29 [234]	9.00 [229]	27.50 [699]	63
5	10	20.00 [508]	47.85 [1215]	11.36 [289]	14.50 [368]	46.25 [1175]	147
6		Consult Cutler-Hammer for Availability					
7							
8							
9							
3 POLE REVERSING CONTACTORS - with or without Control Power Transformers							
0	6	12.01 [305]	14.39 [366]	7.51 [191]	8.00 [203]	13.50 [343]	18
1	6	12.01 [305]	14.39 [366]	7.51 [191]	8.00 [203]	13.50 [343]	19
2	6	12.01 [305]	14.39 [366]	7.51 [191]	8.00 [203]	13.50 [343]	19
3	8	14.25 [362]	29.10 [739]	9.29 [234]	9.00 [229]	27.50 [699]	47
4	8	14.25 [362]	29.10 [739]	9.29 [234]	9.00 [229]	27.50 [699]	69
5	10	20.00 [508]	47.85 [1215]	11.36 [289]	14.50 [368]	46.25 [1175]	170
6		Consult Cutler-Hammer for Availability					
7							
8							
9							

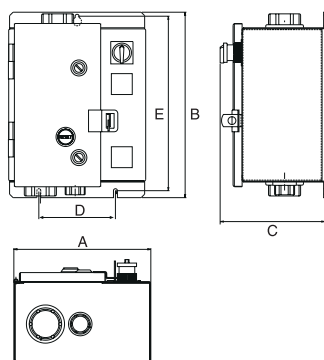

BOXES 5, 6

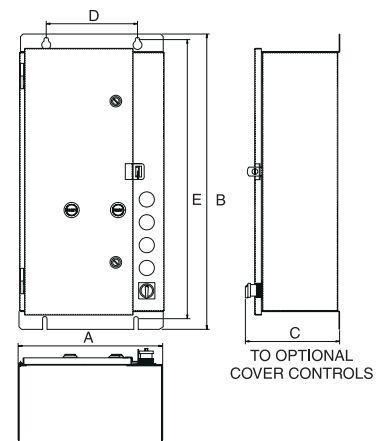

BOXES 8, 10

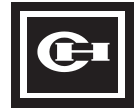

NEMA, Contactors & Starters, (Freedom)

APPROXIMATE DIMENSIONS AND SHIPPING WEIGHTS (Continued)

Do not use for construction.

NON-REVERSING & REVERSING STARTERS — ENCLOSED TYPE NEMA 1

NEMA Size (poles)	Box No.	Dimensions in Inches [mm]					Ship Wt. Lbs.
		Wide A	High B	Deep C	Mounting		
					Wide D	High E	
NON-REVERSING STARTERS Without Control Power Transformers							
00	1	5.62 [143]	10.09 [256]	5.71 [145]	4.50 [114]	8.00 [203]	7
00 with top adders	3	12.65 [321]	14.40 [366]	7.31 [186]	9.75 [248]	11.25 [286]	10
0	1	5.62 [143]	10.09 [256]	5.71 [145]	4.50 [114]	8.00 [203]	7.1
0 with top adders	3	12.65 [321]	14.40 [366]	7.31 [186]	9.75 [248]	11.25 [286]	10
1	1	5.62 [143]	10.09 [256]	5.71 [145]	4.50 [114]	8.00 [203]	7.9
1 with top adders	3	12.65 [321]	14.40 [366]	7.31 [186]	9.75 [248]	11.25 [286]	11.5
2	2	7.73 [196]	13.21 [336]	6.75 [172]	6.00 [152]	10.75 [273]	8.5
3	4	11.66 [296]	26.51 [673]	8.89 [226]	9.00 [229]	23.38 [594]	35
4	4	11.66 [296]	26.51 [673]	8.89 [226]	9.00 [229]	23.38 [594]	47
5	10	20.00 [508]	47.85 [1215]	11.36 [289]	14.50 [368]	46.25 [1175]	139
6		Consult Cutler-Hammer for Availability					
7							
8							
9							
NON-REVERSING STARTERS With Control Power Transformers							
00	3	12.65 [321]	14.40 [366]	7.31 [186]	9.75 [248]	11.25 [286]	15
0	3	12.65 [321]	14.40 [366]	7.31 [186]	9.75 [248]	11.25 [286]	15
1	3	12.65 [321]	14.40 [366]	7.31 [186]	9.75 [248]	11.25 [286]	16
2	3	12.65 [321]	14.40 [366]	7.31 [186]	9.75 [248]	11.25 [286]	16.2
3	4	11.66 [296]	26.51 [673]	8.89 [226]	9.00 [229]	23.38 [594]	42
4	4	11.66 [296]	26.51 [673]	8.89 [226]	9.00 [229]	23.38 [594]	54
5	10	20.00 [508]	47.85 [1215]	11.36 [289]	14.50 [368]	46.25 [1175]	146
6		Consult Cutler-Hammer for Availability					
7							
8							
9							
REVERSING STARTERS Without Control Power Transformers							
00	2	7.73 [196]	13.21 [336]	6.75 [172]	6.00 [152]	10.75 [273]	8
0	2	7.73 [196]	13.21 [336]	6.75 [172]	6.00 [152]	10.75 [273]	8
0 with top adders	3	12.65 [321]	14.40 [366]	7.31 [186]	9.75 [248]	11.25 [286]	11
1 with top adders	3	12.65 [321]	14.40 [366]	7.31 [186]	9.75 [248]	11.25 [286]	13.4
2	3	12.65 [321]	14.40 [366]	7.31 [186]	9.75 [248]	11.25 [286]	15
3	4	11.66 [296]	26.51 [673]	8.89 [226]	9.00 [229]	23.38 [594]	43
4	9	25.50 [648]	29.10 [739]	9.31 [237]	20.00 [508]	27.50 [699]	65
5	10	20.00 [508]	47.85 [1215]	11.36 [289]	14.50 [368]	46.25 [1175]	165
6		Consult Cutler-Hammer for Availability					
7							
8							
9							
REVERSING STARTERS With Control Power Transformers							
00 with top adders	3	12.65 [321]	14.40 [366]	7.31 [186]	9.75 [248]	11.25 [286]	15
0	3	12.65 [321]	14.40 [366]	7.31 [186]	9.75 [248]	11.25 [286]	15
0 with top adders	3	12.65 [321]	14.40 [366]	7.31 [186]	9.75 [248]	11.25 [286]	17
2	3	12.65 [321]	14.40 [366]	7.31 [186]	9.75 [248]	11.25 [286]	19
3	4	11.66 [296]	26.51 [673]	8.89 [226]	9.00 [229]	23.38 [594]	50
4	9	25.50 [648]	29.10 [739]	9.31 [237]	20.00 [508]	27.50 [699]	72
5	10	20.00 [508]	47.85 [1215]	11.36 [289]	14.50 [368]	46.25 [1175]	172
6		Consult Cutler-Hammer for Availability					
7							
8							
9							

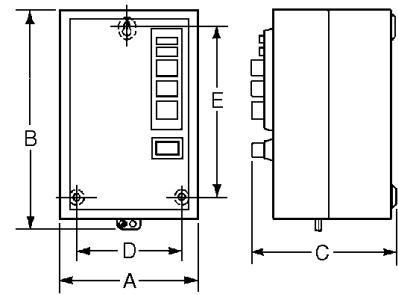

BOXES 1-4

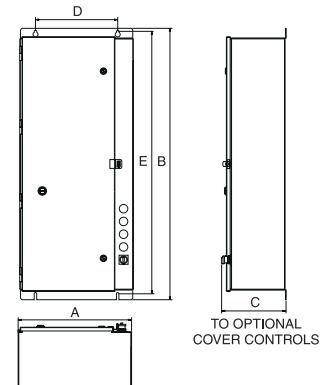

BOXES 9-10

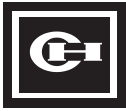

NEMA, Contactors & Starters, (Freedom)

APPROXIMATE DIMENSIONS AND SHIPPING WEIGHTS (Continued)

Do not use for construction.

NON-REVERSING & REVERSING STARTERS — ENCLOSED TYPE NEMA 3R, 4/4X & 12

NEMA Size (poles)	Box No.	Dimensions in Inches [mm]					Ship Wt. Lbs.
		Wide A	High B	Deep C	Mounting		
					Wide D	High E	
NON-REVERSING STARTERS - without Control Power Transformers							
0	5	9.84 [250]	13.31 [338]	7.51 [191]	5.50 [140]	12.50 [318]	14.3
1	5	9.84 [250]	13.31 [338]	7.51 [191]	5.50 [140]	12.50 [318]	15.3
2	6	12.01 [305]	14.39 [366]	7.51 [191]	8.00 [203]	13.50 [343]	16
3	8	14.25 [362]	29.10 [739]	9.29 [234]	9.00 [229]	27.50 [699]	46
4	8	14.25 [362]	29.10 [739]	9.29 [234]	9.00 [229]	27.50 [699]	60
4	9	25.50 [648]	29.10 [739]	9.31 [237]	20.00 [508]	27.50 [699]	60
5	10	20.00 [508]	47.85 [1215]	11.36 [289]	14.50 [368]	46.25 [1175]	150
6		Consult Cutler-Hammer for Availability					
7							
8							
9							
NON-REVERSING STARTERS - with Control Power Transformers							
0	6	12.01 [305]	14.39 [366]	7.51 [191]	8.00 [203]	13.50 [343]	18
1	6	12.01 [305]	14.39 [366]	7.51 [191]	8.00 [203]	13.50 [343]	19
2	6	12.01 [305]	14.39 [366]	7.51 [191]	8.00 [203]	13.50 [343]	20
3	8	14.25 [362]	29.10 [739]	9.29 [234]	9.00 [229]	27.50 [699]	53
4	8	14.25 [362]	29.10 [739]	9.29 [234]	9.00 [229]	27.50 [699]	67
4	9	25.50 [648]	29.10 [739]	9.31 [237]	20.00 [508]	27.50 [699]	67
5	10	20.00 [508]	47.85 [1215]	11.36 [289]	14.50 [368]	46.25 [1175]	157
6		Consult Cutler-Hammer for Availability					
7							
8							
9							
REVERSING STARTERS - with or without Control Power Transformers							
0	6	12.01 [305]	14.39 [366]	7.51 [191]	8.00 [203]	13.50 [343]	18.5
1	6	12.01 [305]	14.39 [366]	7.51 [191]	8.00 [203]	13.50 [343]	19.5
2	6	12.01 [305]	14.39 [366]	7.51 [191]	8.00 [203]	13.50 [343]	21
1-2	7	16.26 [413]	14.37 [365]	7.51 [191]	11.00 [279]	13.50 [343]	24
3	8	14.25 [362]	29.10 [739]	9.29 [234]	9.00 [229]	27.50 [699]	48
4	9	25.50 [648]	29.10 [739]	9.31 [237]	20.00 [508]	27.50 [699]	72
5	10	20.00 [508]	47.85 [1215]	11.36 [289]	14.50 [368]	46.25 [1175]	175
6		Consult Cutler-Hammer for Availability					
7							
8							
9							

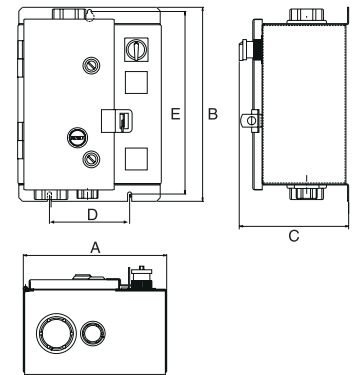

BOXES 5, 6, 7, 9

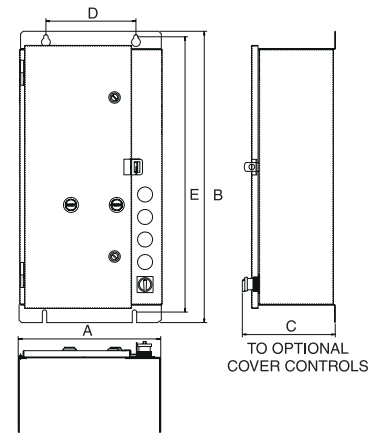

BOXES 8, 10

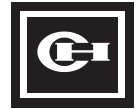

NEMA, Contactors & Starters, (Freedom)

WIRING DIAGRAMS

NON-REVERSING STARTERS

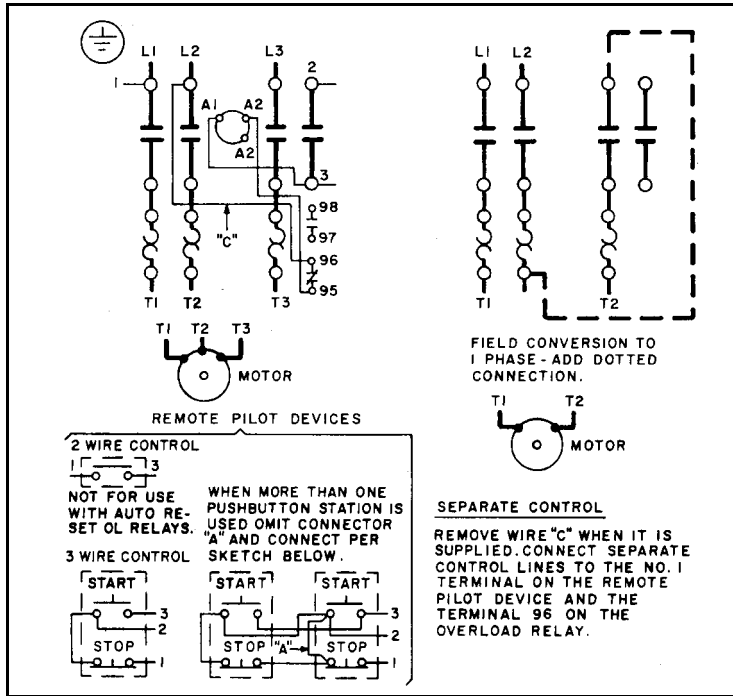

SIZE 00

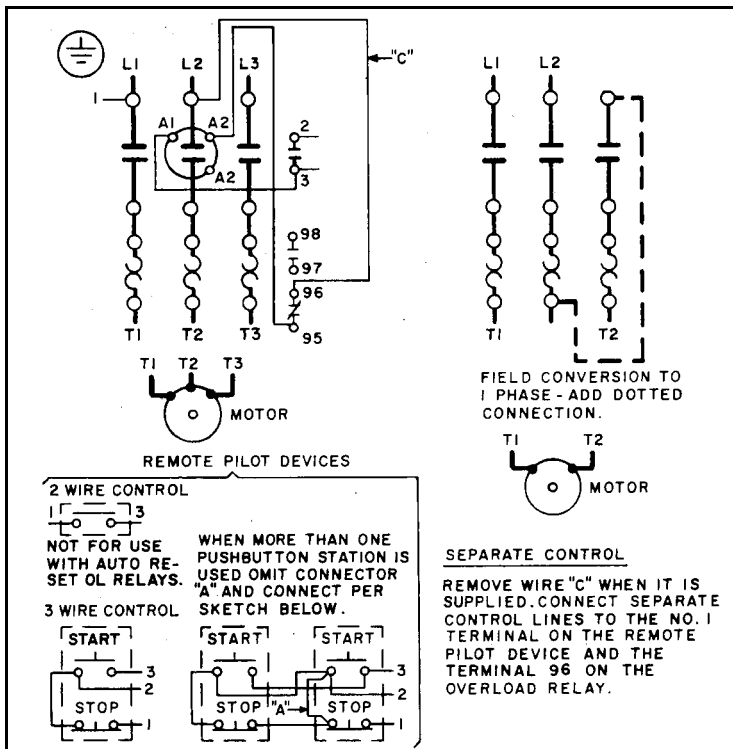

SIZE 0

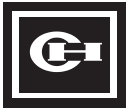

NEMA, Contactors & Starters, (Freedom)

WIRING DIAGRAMS (Continued)

NON-REVERSING STARTERS (Continued)

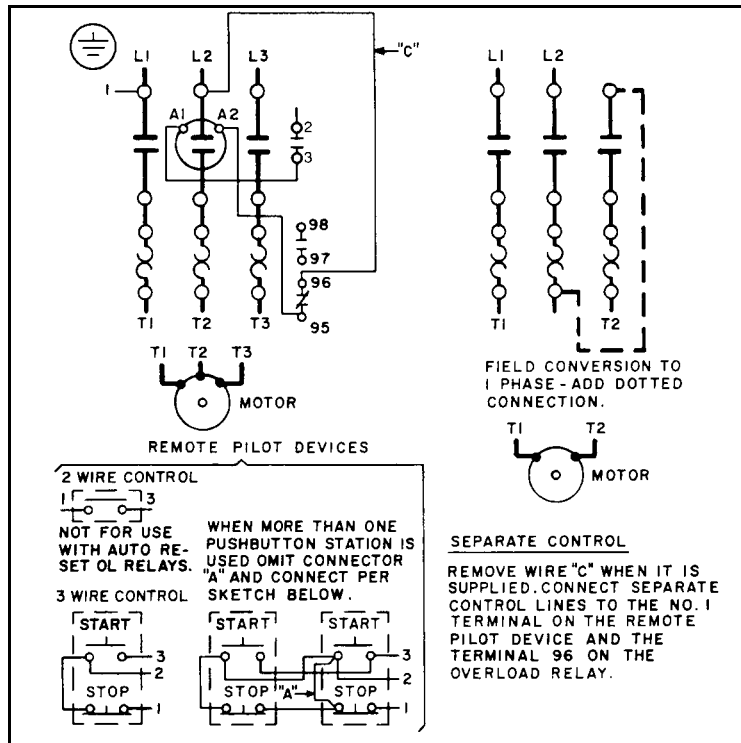

SIZES 1 & 2

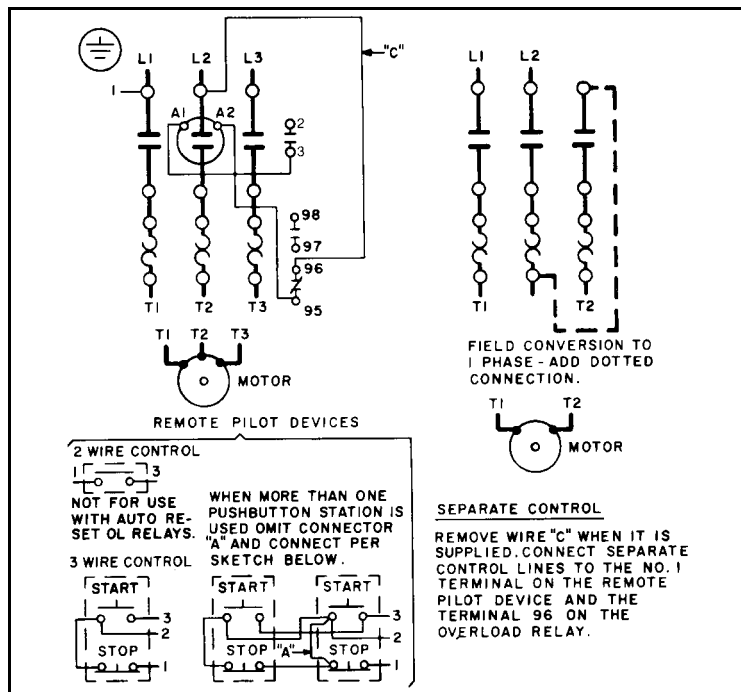

SIZE 3



NEMA, Contactors & Starters, (Freedom)

WIRING DIAGRAMS (Continued)

NON-REVERSING STARTERS (Continued)

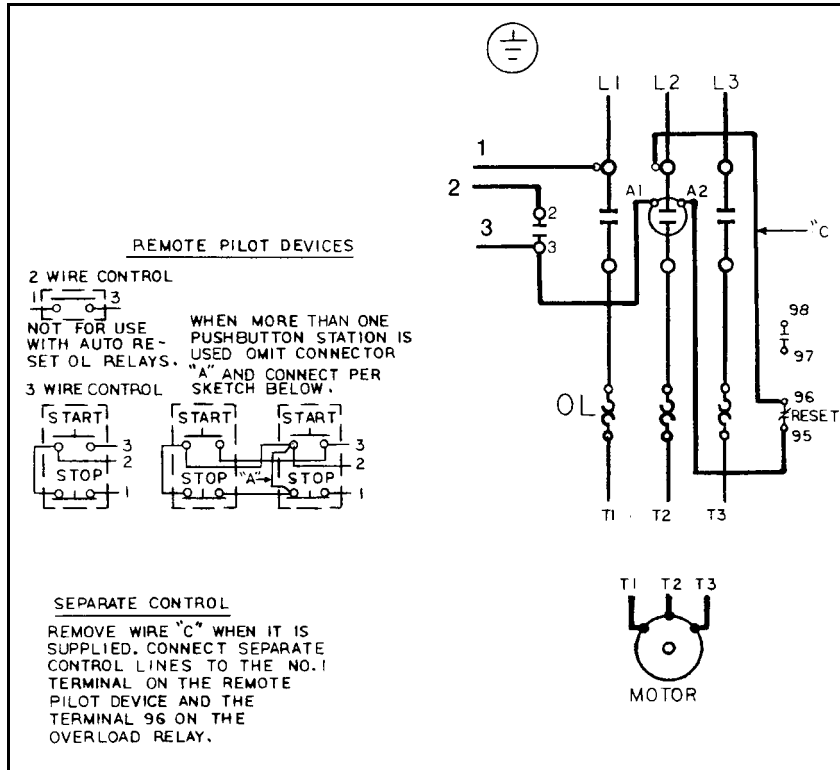

SIZE 4

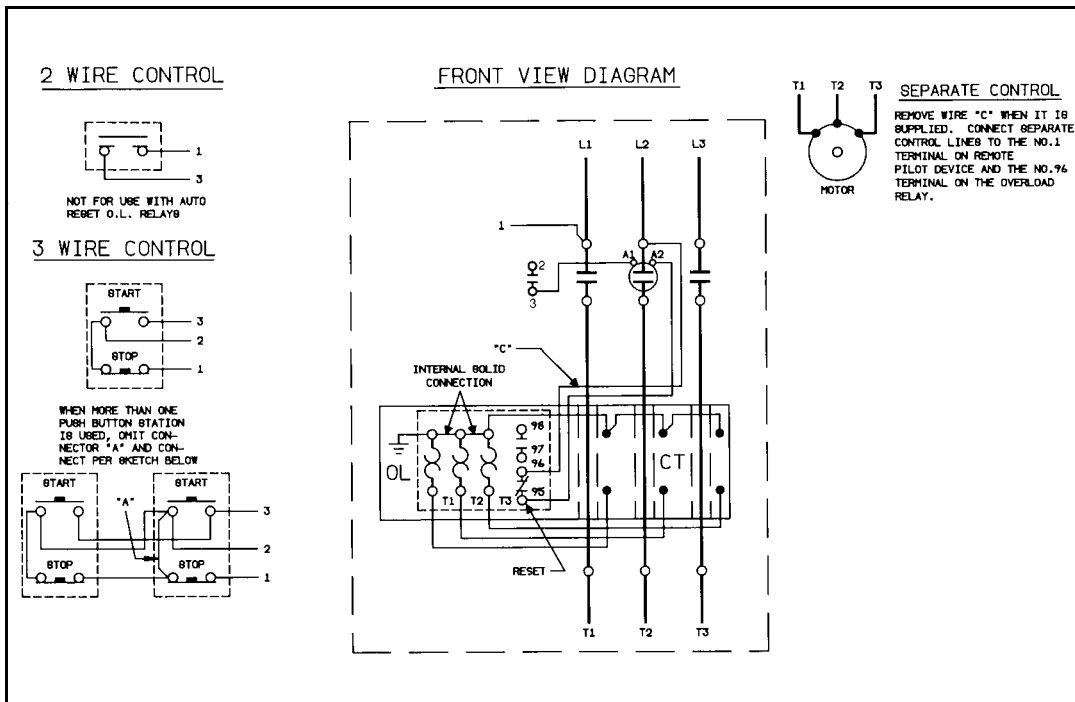

SIZE 5

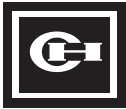

NEMA, Contactors & Starters, (Freedom)

WIRING DIAGRAMS (Continued)

NON-REVERSING STARTERS (Continued)

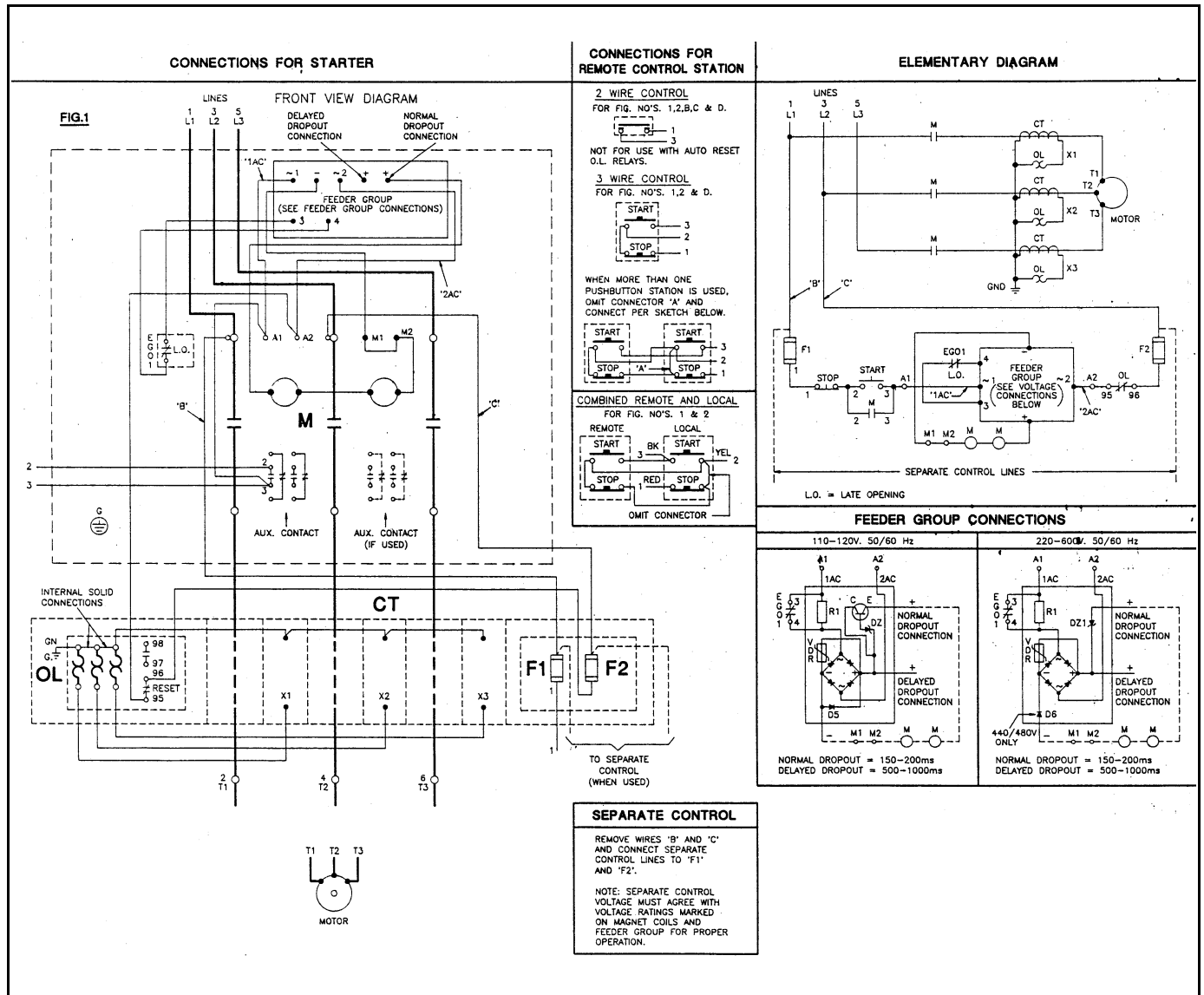

SIZE 6

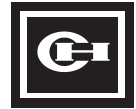

NEMA, Contactors & Starters, (Freedom)

WIRING DIAGRAMS (Continued)

NON-REVERSING STARTERS (Continued)

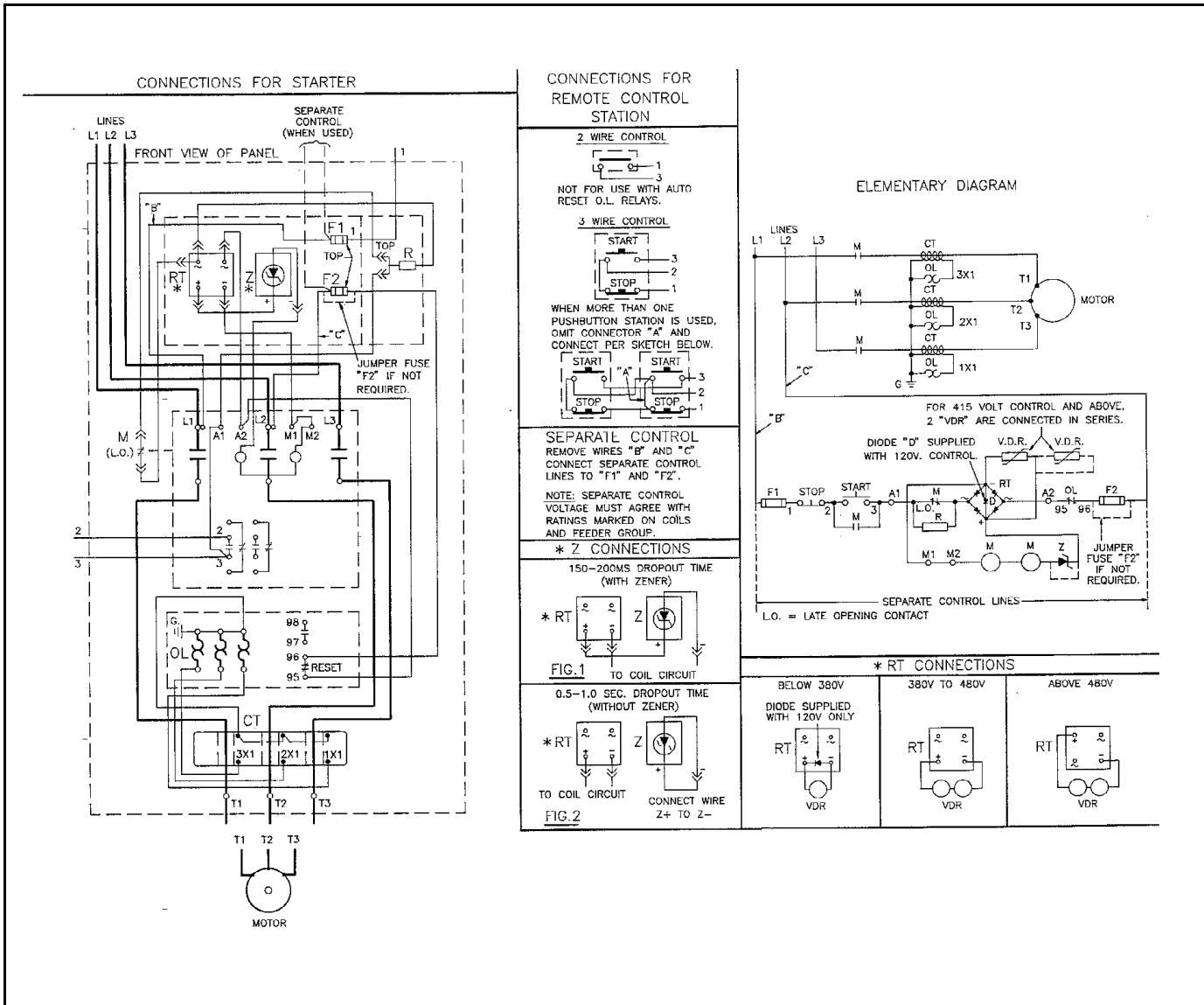

SIZE 7

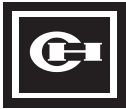

NEMA, Contactors & Starters, (Freedom)

WIRING DIAGRAMS (Continued)

NON-REVERSING STARTERS (Continued)

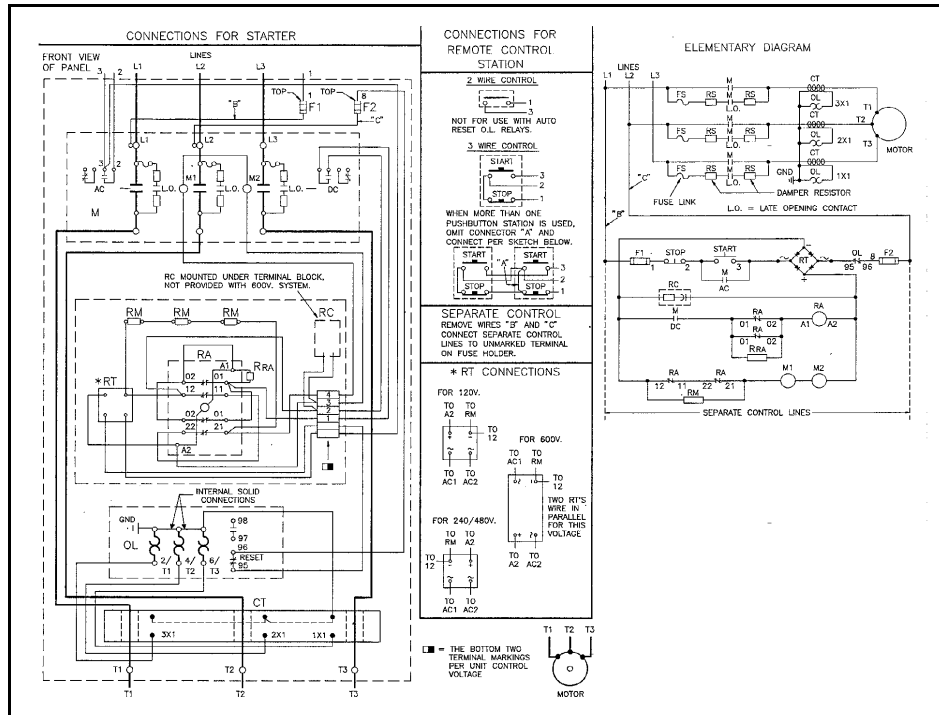

SIZE 8

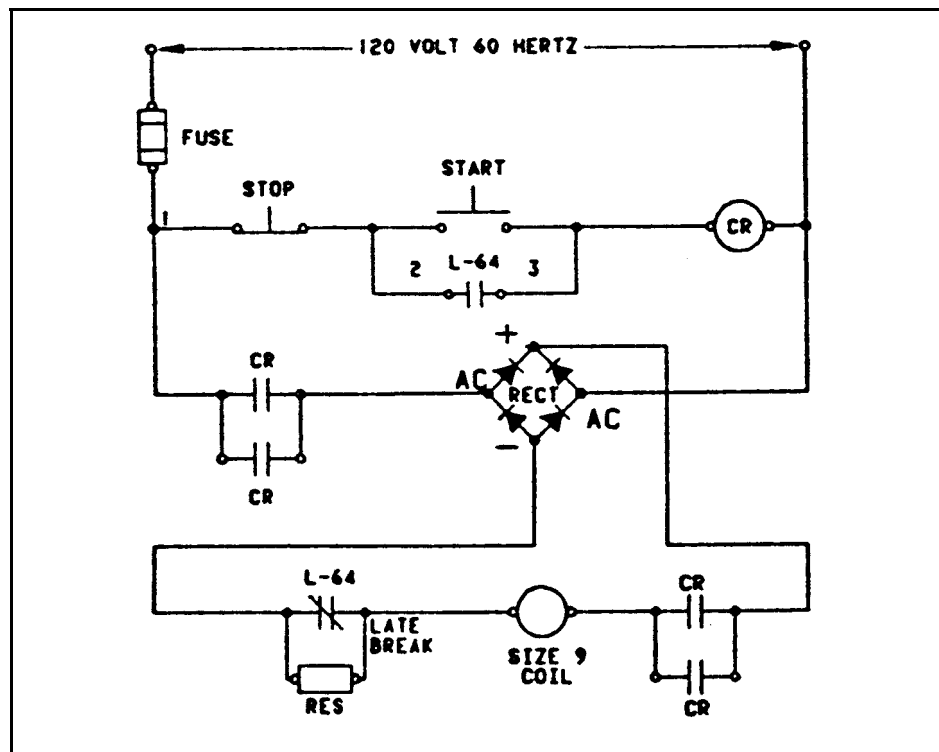

SIZE 9 CONTROL CIRCUIT

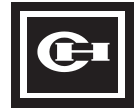

NEMA, Contactors & Starters, (Freedom)

WIRING DIAGRAMS (Continued)

TYPICAL DC CONTROL WIRING DIAGRAM

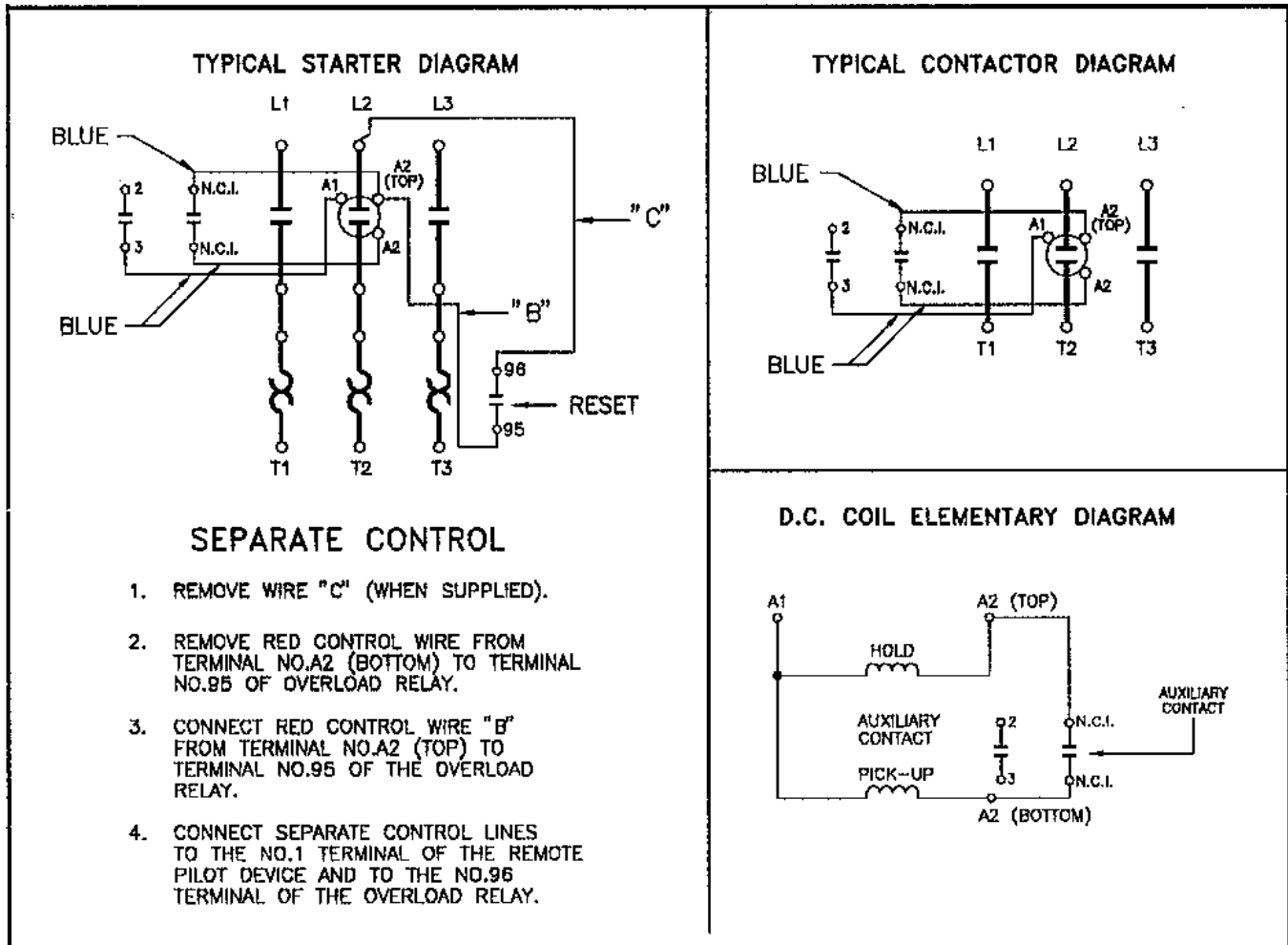

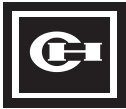

NEMA, Contactors & Starters, (Freedom)

WIRING DIAGRAMS (Continued)

REVERSING STARTERS

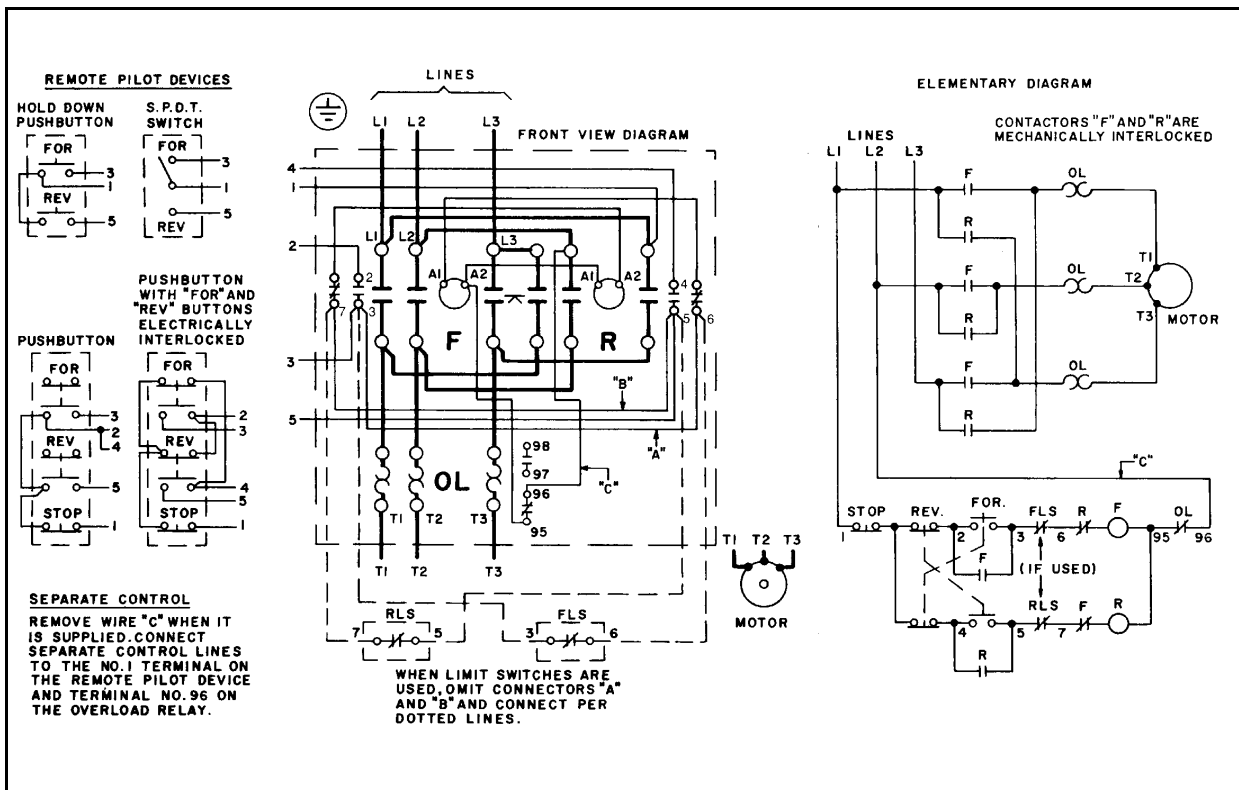
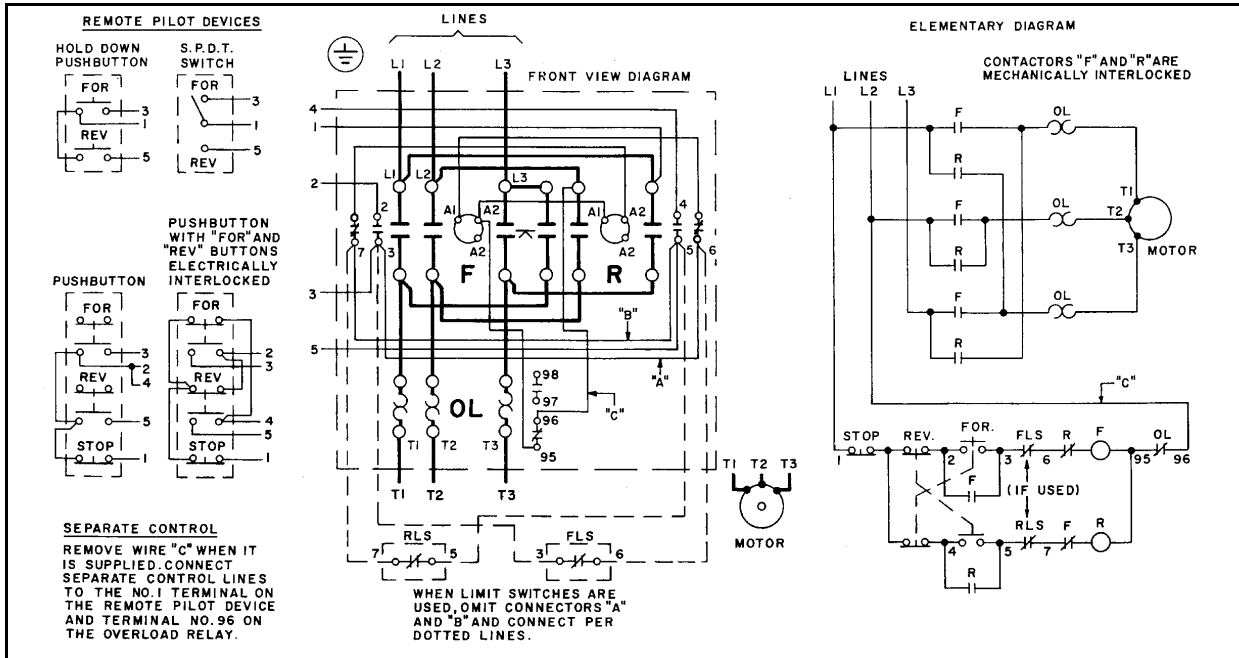

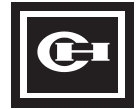

NEMA, Contactors & Starters, (Freedom)

WIRING DIAGRAMS (Continued)

REVERSING STARTERS (Continued)

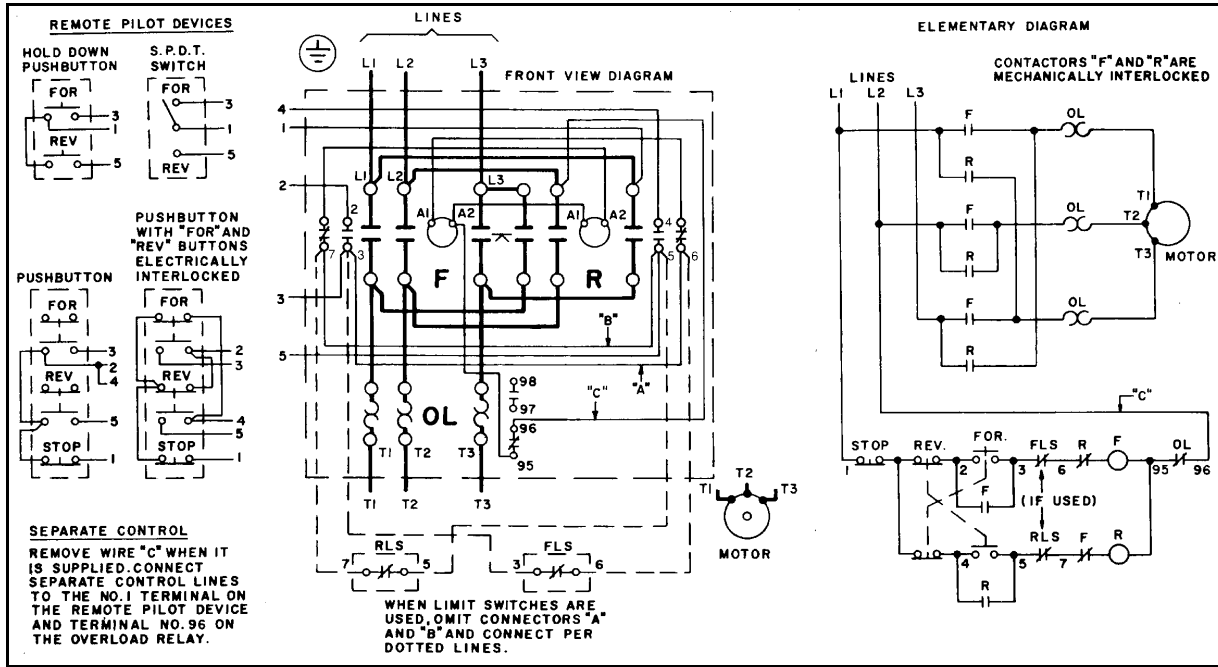

SIZE 3

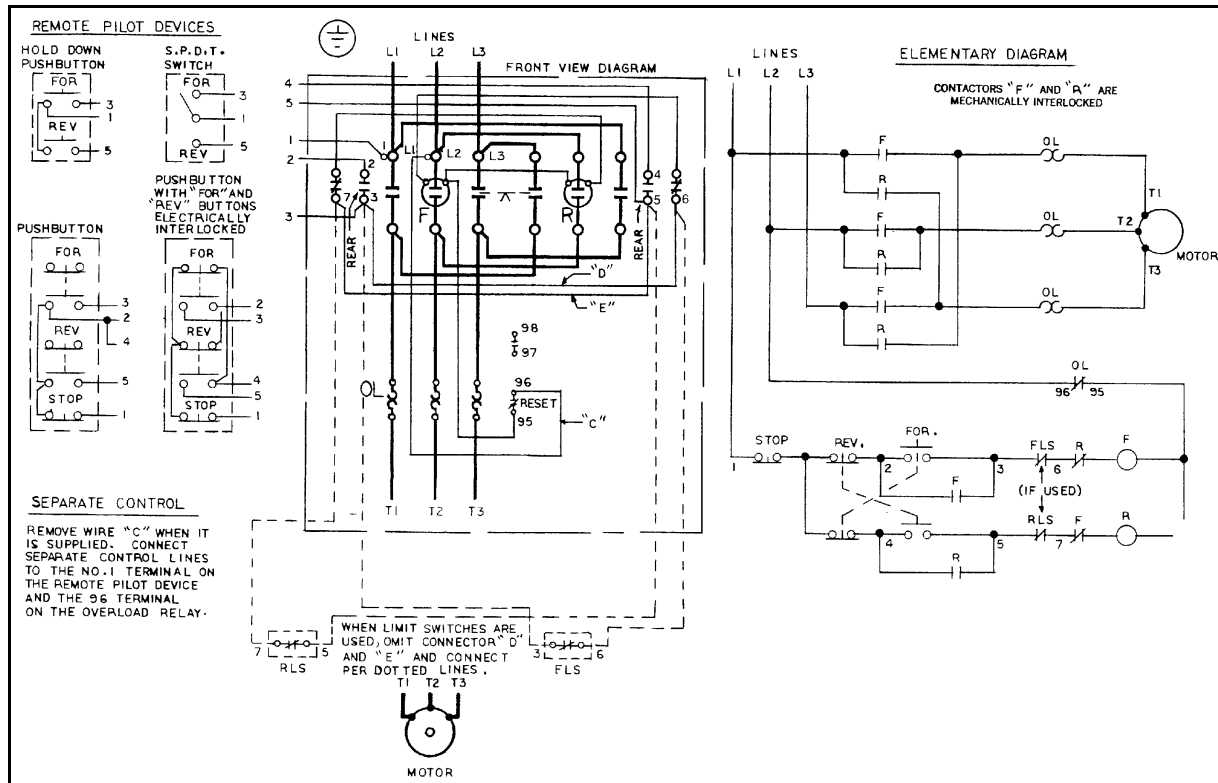

SIZE 4



NEMA, Contactors & Starters, (Freedom)

WIRING DIAGRAMS (Continued)

REVERSING STARTERS (Continued)

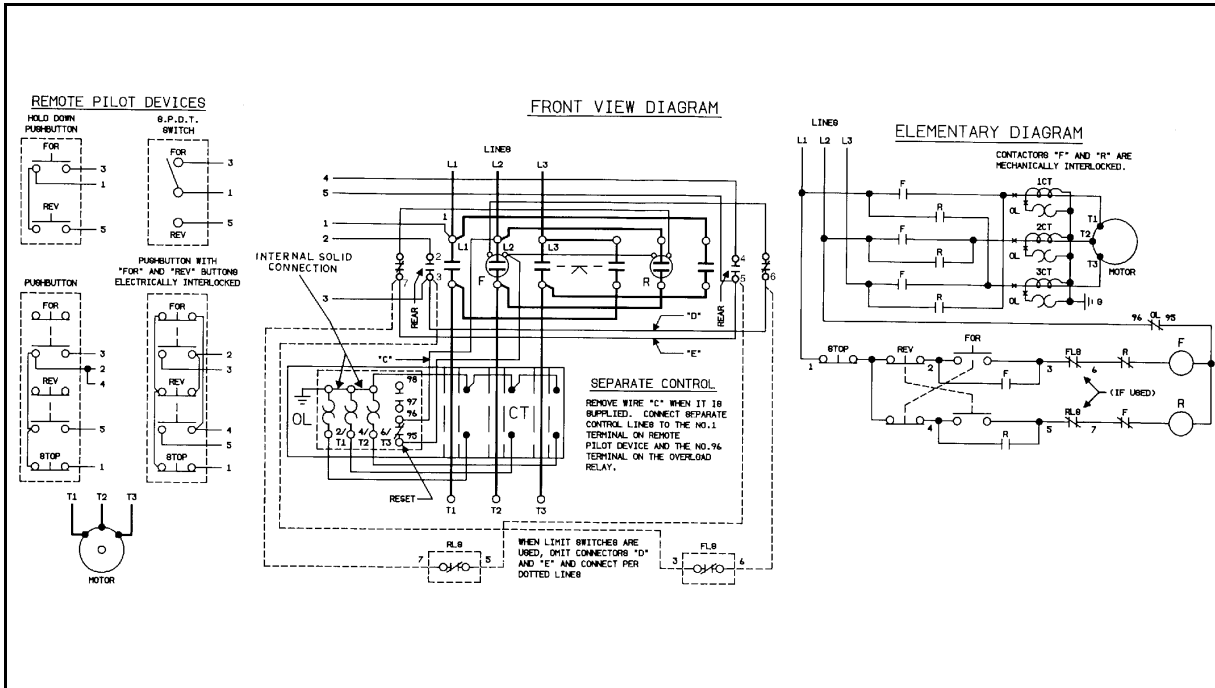

SIZE 5

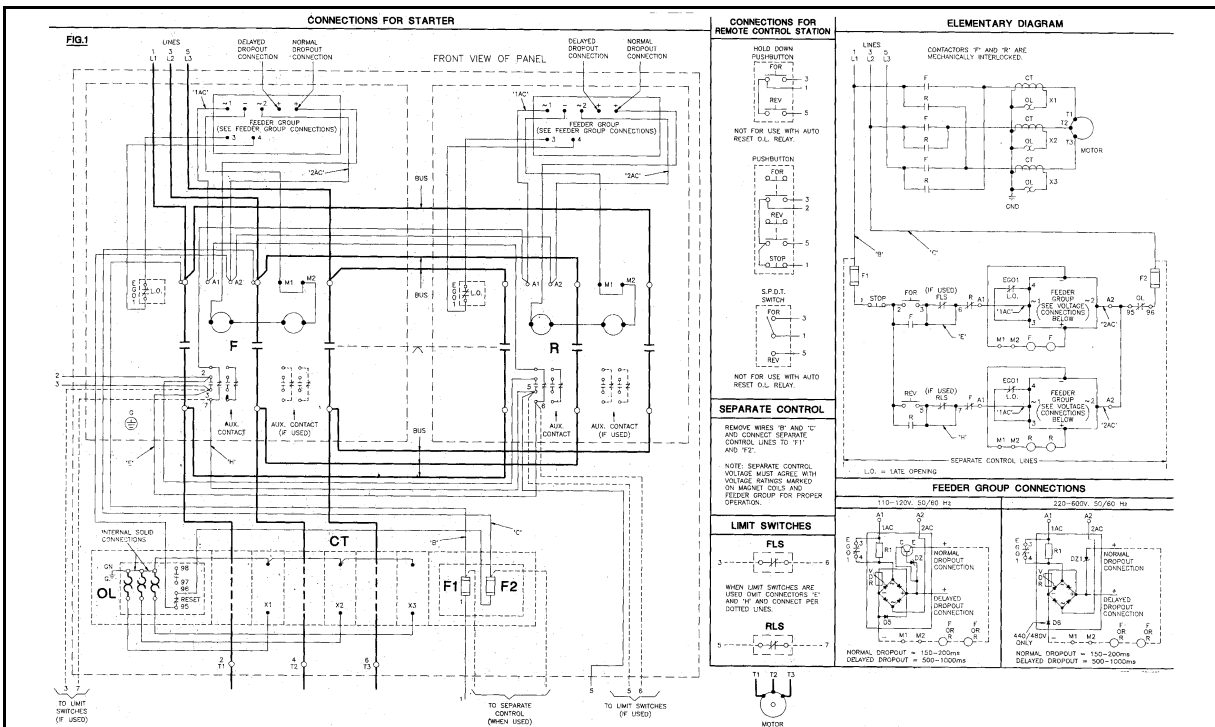

SIZE 6



NEMA, Contactors & Starters, (Freedom)

WIRING DIAGRAMS (Continued)

REVERSING STARTERS (Continued)

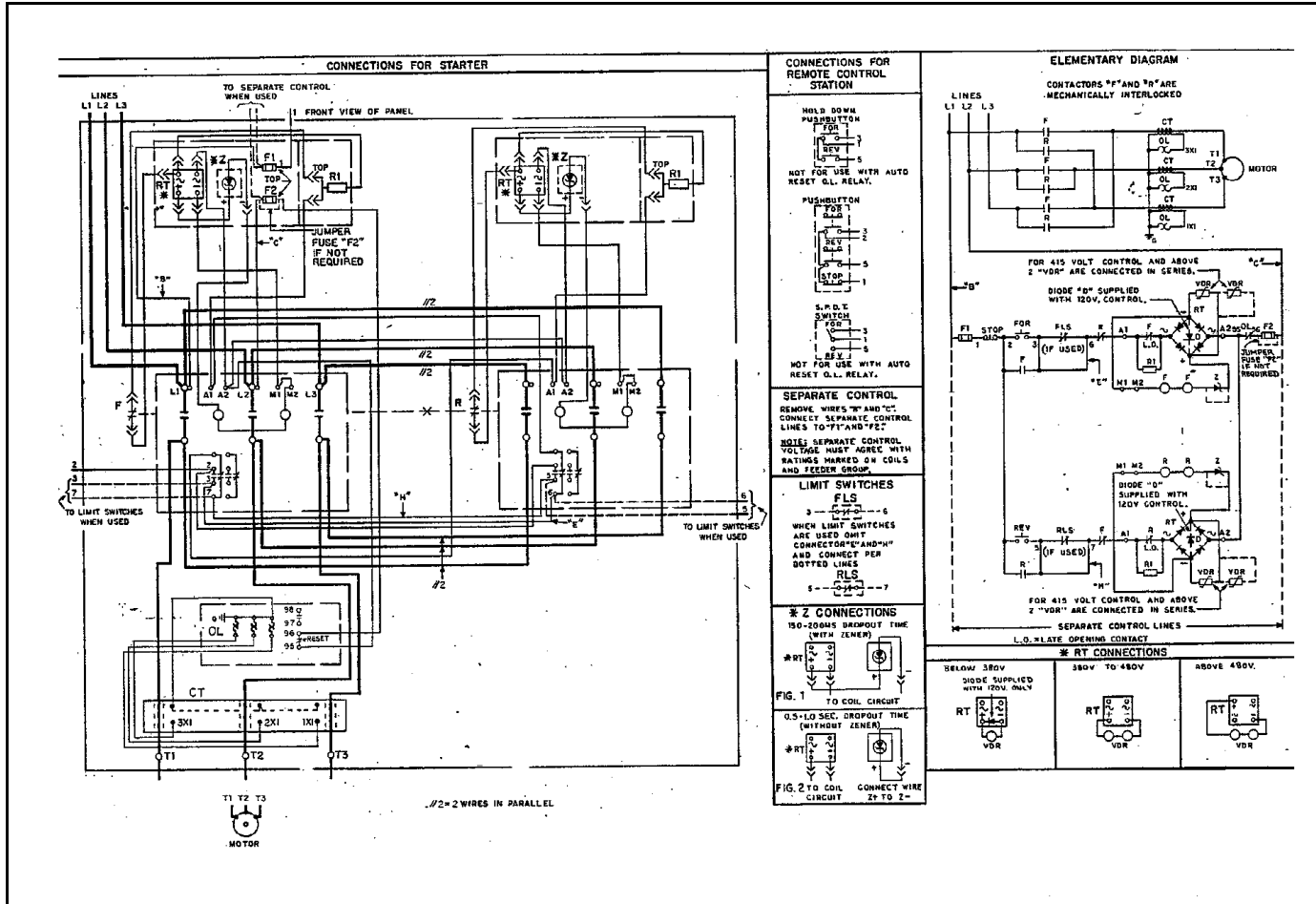

SIZE 7

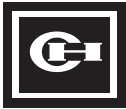

NEMA, Contactors & Starters, (Freedom)

WIRING DIAGRAMS (Continued)

REVERSING STARTERS (Continued)

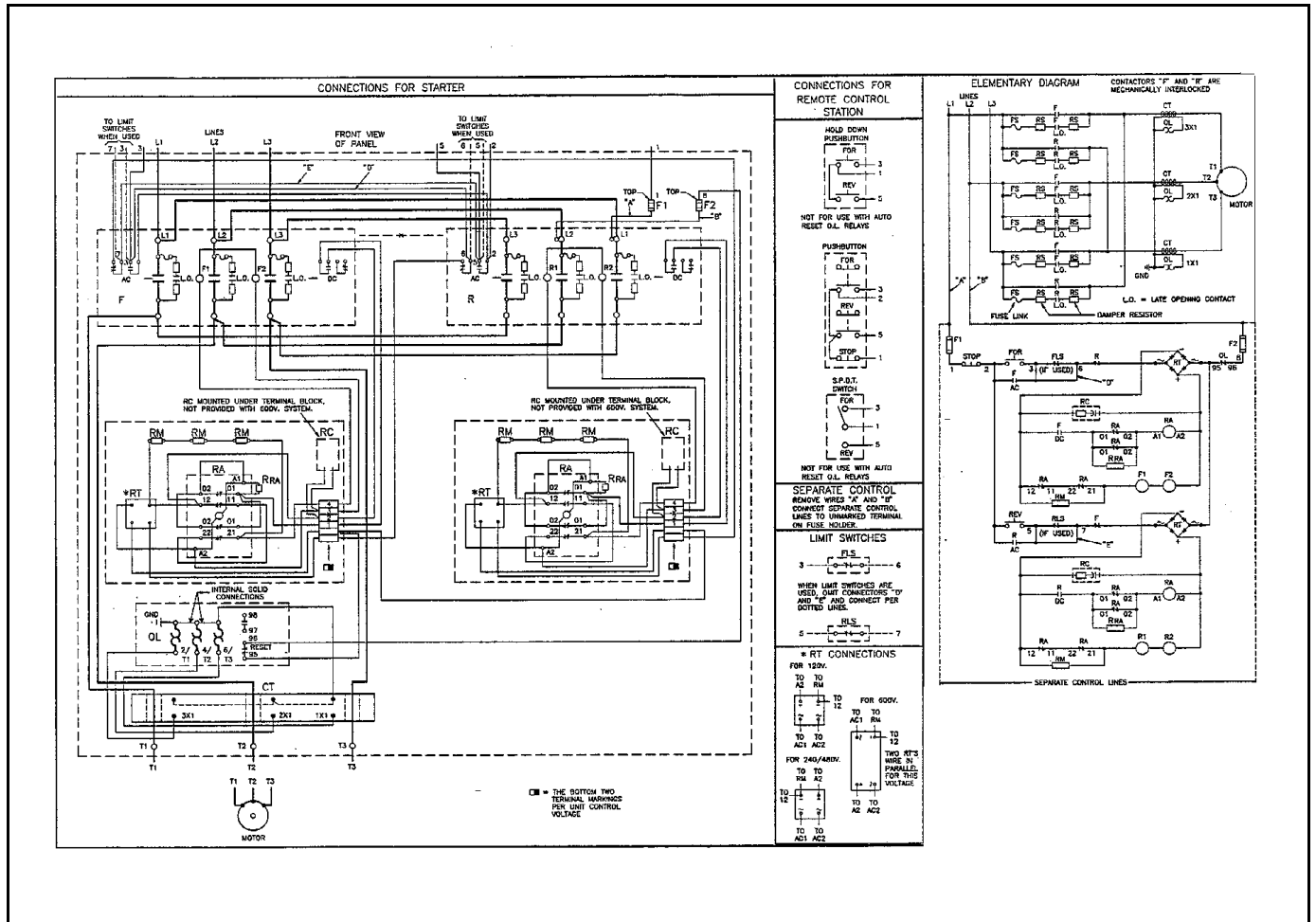

SIZE 8



NEMA, Contactors & Starters, (Freedom)

WIRING DIAGRAMS (Continued)

REVERSING STARTERS (Continued)

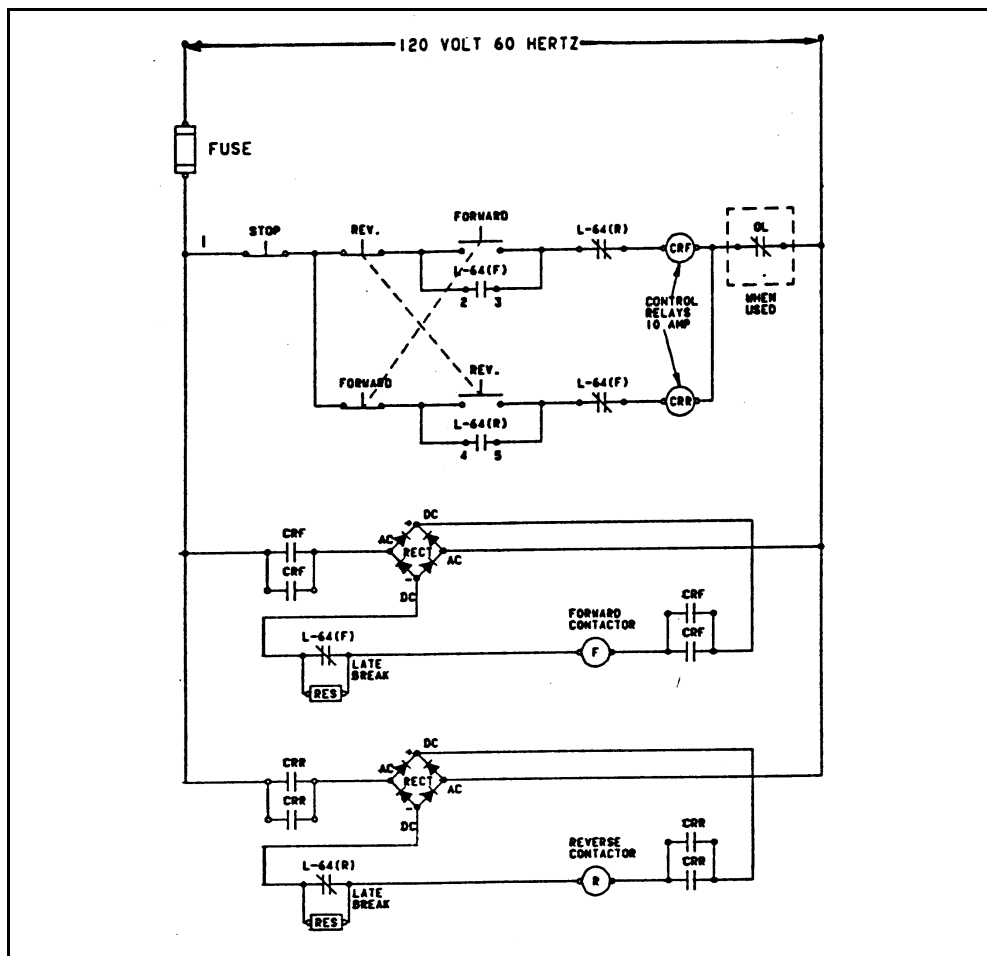

SIZE 9 — CONTROL CIRCUIT

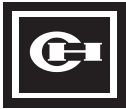

NEMA, Contactors & Starters, (Freedom)

WIRING DIAGRAMS (Continued)

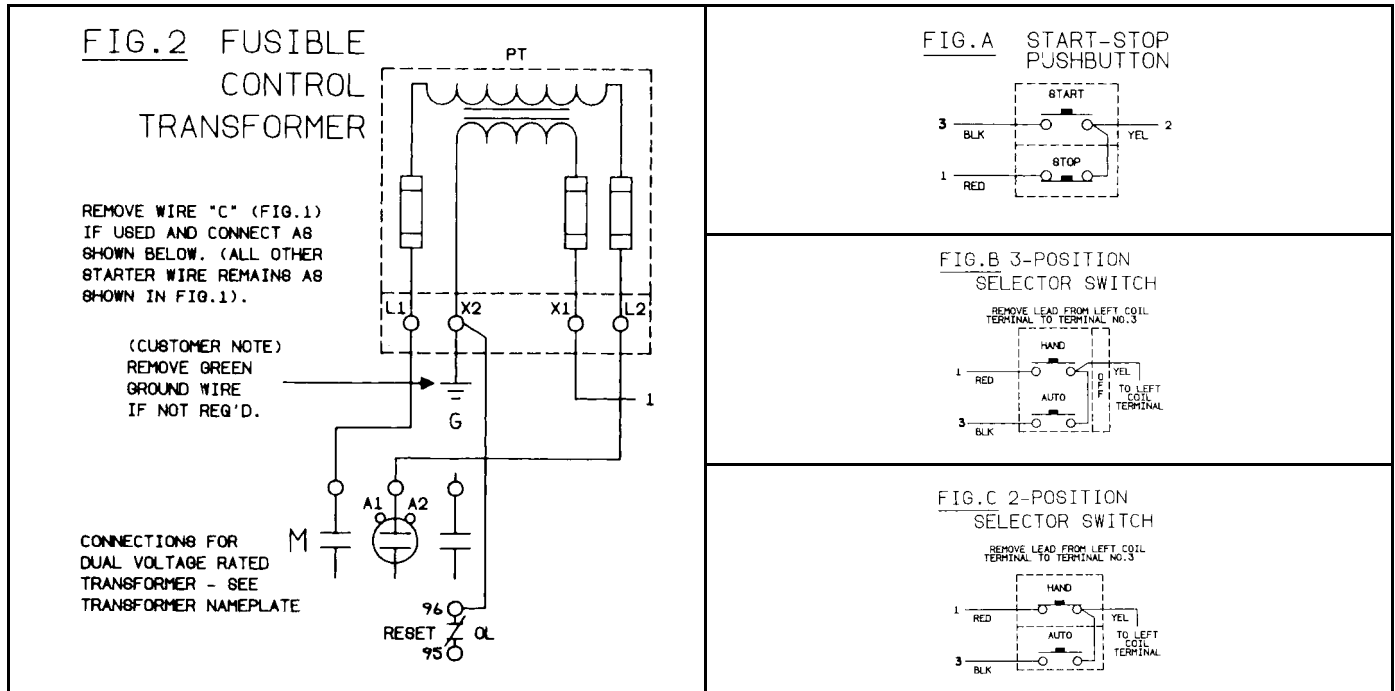

ACCESSORIES

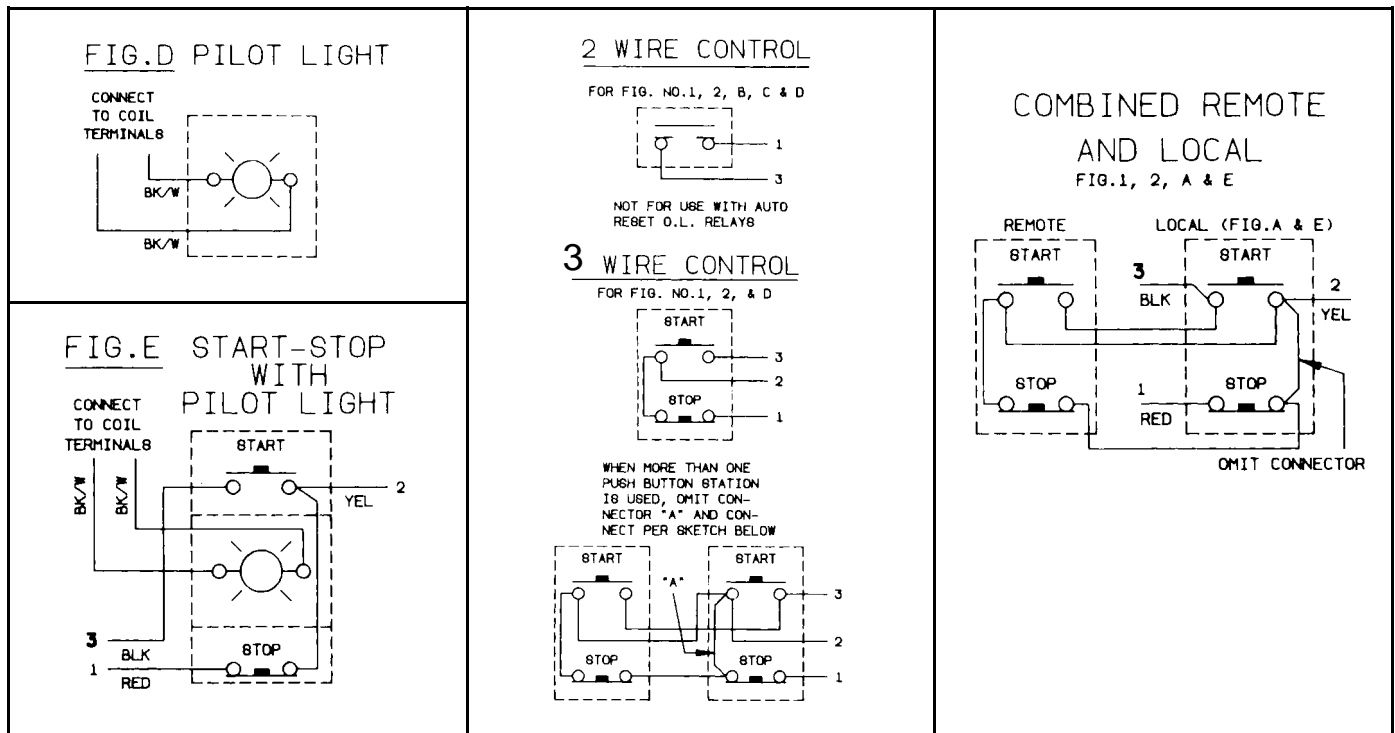

ACCESSORIES